

SECTION C

49000 SERIES CHASSIS SHEET METAL

CONTENTS

Division	Subject	Paragraph
I	TROUBLE DIAGNOSIS: Hood Noises or Panel Flutter	110-18
II	DESCRIPTION AND OPERATION: Description of Chassis Sheet Metal	110-19
III	ADJUSTMENTS AND MINOR SERVICE: Fender, Bumper and Hood Alignment Inspection Fender, Bumper and Hood Adjustment	110-20 110-21
IV	REMOVAL AND INSTALLATION: Hood Assembly Hood Hinge Spring Hood Hinge Fender and Skirt	110-22 110-23 110-24 110-25
V	OVERHAUL AND MAJOR SERVICE: (Not Applicable)	-
VI	SPECIFICATIONS: (Not Applicable)	-

110C-1

DIVISION I

TROUBLE DIAGNOSIS

110-18 HOOD NOISES OR PANEL FLUTTER

Squeaks or grunting noises in the hood when driving over rough roads do not necessarily indicate misalignment of hood or fenders. These noises may be caused by metal contact at some point where clearance should exist or by worn or dry hood bumpers.

If the hood squeaks, check for uniform clearance all around the hood and fenders. If an edge of metal is making contact at any point where clearance should exist, a bright

metal spot will usually be found. Such spots may be depressed by spring hammering to provide clearance.

A grunting noise in the hood is usually caused by dry rubber bumpers on fender rails and cowl ledge lacing. Lubricate all rubber bumpers on fender rails and cowl with silicone rubber lubricant. To correct a persistent case of squeaking or grunting where hood to panel contacts ledge lacing, even when lubricated, cement a 1/16" thick strip of felt to panel where the lacing makes contact.

To prevent hood panel flutter, the rear end of the hood panel must have firm contact with the rubber bumpers and lacing attached to cowl ledge. The hood may be raised or lowered by adjusting rear adjustable bumpers. See paragraph 110-21, sub-paragraph c.

DIVISION II

DESCRIPTION AND OPERATION

110-19 DESCRIPTION OF CHASSIS SHEET METAL

a. Chassis Sheet Metal Assembly

The chassis sheet metal assembly is attached to the frame and body at adjustment points. The front of the assembly is supported by two mounts located at the frame side rails. Shims at these locations allow up and down movement of the front of the sheet metal assembly. Fore and aft and side adjustment is allowed by oversize holes at the fender rear attaching points and chassis sheet metal mounts. Special shims at the rear locations allow adjustment of the rear of the assembly. The lower rear edge of the assembly is attached to the body at the rocker panel by bolts on each side. Shims are used at this location to provide up and down adjustment at the rear of the fender.

IMPORTANT: *The bolts that retain the sheet metal braces must be torqued to the required torques. If these bolts are loose, the braces will not provide additional support for the sheet metal assembly.*

b. Hood, Hinges and Latch Mechanism

The hood panel is of one piece construction, strengthened and held to shape by a reinforcement of stamped sheet metal.

The rear of the hood assembly is attached to the body cowl and fender on each side by hinge assemblies which permit the front of the hood to be raised. A heavy coil spring connected between each hinge assembly assists in the open position.

The front of the hood is held down by a ratchet-type hood latch which is cable released from inside the passenger compartment. After the latch is released, a secondary latch must be hand released at the front of the hood. This secondary latch is mounted to the hood inner panel and engages the opening in the side of the grille support.

NOTE: THIS HOOD LOCK CATCH ASSEMBLY TO RADIATOR GRILL CENTER SUPPORT FASTENER IS AN IMPORTANT ATTACHING PART IN THAT IT COULD AFFECT THE PERFORMANCE OF VITAL COMPONENTS AND SYSTEMS, AND/OR COULD RESULT IN MAJOR REPAIR EXPENSE. IT MUST BE REPLACED WITH ONE OF THE SAME PART NUMBER OR WITH AN EQUIVALENT PART IF REPLACEMENT BECOMES NECESSARY. DO NOT USE A REPLACEMENT PART OF LESSER QUALITY OR SUBSTITUTE DESIGN. TORQUE VALUES MUST BE USED AS SPECIFIED DURING REASSEMBLY TO ASSURE PROPER RETENTION OF THIS PART.

DIVISION III

ADJUSTMENTS AND MINOR SERVICE

110-20 FENDER, BUMPER AND HOOD ALIGNMENT INSPECTION

When the front sheet metal is misaligned, it is imperative to make the correct adjustment since an incorrect move on one item can throw the error to another area. Therefore, it is necessary to analyze the sheet metal as a whole before adjustments are made. For best results, the following procedure should be used:

a. Preliminary Tightening

Before deciding upon any adjustment to correct hood or fender misalignment, it is advisable to check tightness of all attaching screws and bolts since a true picture of the correction requirements cannot be obtained when the sheet metal is loose and free to shift.

After all parts are properly tightened, inspect fender and hood alignment (subpar. b) and hood alignment (subpar. c). Make all inspections before performing any adjustments because an adjustment at one point will usually alter alignment at other points. The preliminary inspection should determine the adjustments that will produce the best overall alignment of hood and fenders at all points.

b. Fender and Hood Alignment at Front Doors

1. Fender to leading edge of door should have a $7/32$ " (approximately) parallel gap and be flush. If realignment is necessary, check what this move will do at the rear end of the hood opening (approximately $1/8$ " gap between fenders and hood.) The total gap of both sides should be approximately $1/4$ " regardless of how the hood is spaced. If moving the fender flush with the door will impair this gap too badly, the door must be moved to make it flush with the fender.

Before making any adjustment of sheet metal to provide necessary clearance, first make sure that front doors are properly aligned in the body openings. If fenders and door panel surfaces are not reasonably flush, correction may be made by loosening the two (2) vertical attachments of fender to upper cowl and one (1) attachment of fender to front of dash (rear of hood hinge); this will allow the upper portion of the door to be moved. If the lower portion of the fender must be realigned for flushness, the fender skirt bracket to body bracket located below steering column should be loosened, the vertical attachment of fender to body at the rear of the wheel opening, and the horizontal attachment of the rear lower portion of fender behind the door. Shims must be removed or added to flush the fender to door at this rear lower location.

2. The fender to top edge of door should be flush and parallel.

3. If the hood to fender gap at the rear is correct, the hood split line should be parallel the full length of the hood with the nose of the hood parallel to the front end panel.

4. The hood should be flush with the fenders from front to rear. When the hood and fender split lines are parallel from front to rear and the hood front end is not parallel to the front end panel, it is necessary to shift the front end of the chassis sheet metal (attached at chassis frame on each side of radiator) in the direction of the smaller gap. Some variation of parallel lines and hood to fender nose flushness can be allowed in mild cases, but shifting the sheet metal is the only way a correct alignment can be obtained. Before you have decided this is the move to make, be sure that the rear ends of the fenders are not inboard to the door on one side and outboard on the other; this will have the same effect on out-of-square sheet metal. The hood is the final adjustment item on sheet metal and will not fit in and meet specification in an opening that is not square.

c. Hood Alignment Inspection

When the hood is closed and latched, it should bear firmly against the front rubber bumpers on upper tie bar. Height of hood and width of space between hood and fenders should be reasonably even from front to rear.

110-21 FENDER BUMPER AND HOOD ADJUSTMENT

a. Poor Fender to Door Gap (But Parallel)

To move a fender fore or aft, it is necessary to loosen all attachments to the body (two at the hood hinge area, one at the front of dash slightly below the hood hinge, one at the lower portion of dash attaching to inner fender skirt, and two at the rocker-rear lower end of fender).

Many times after loosening these attachments, the fender will spring to its proper position. If the move isn't too great, the fender can be slightly forced to its correct position; but if too much force is necessary to obtain this setting, further procedures should be used. (Remember that putting the fender under severe strain can result in only a temporary alignment or a changing in the door line or hood split line contour, this can also cause the fender at the rocker at the rear of the wheel cut to flare out or in.)

When a major move is necessary, remove the battery and battery base and loosen all sheet metal attachments of the chassis sheet metal to radiator support of both fenders even if only one is to be relocated. Bolts to loosen are fender skirt (wheel house panel) radiator support, fender to radiator support (behind headlamps). Do not loosen the upper tie bar to fender bolts. Loosen the chassis sheet metal to frame bolts located at each side of the radiator on the side to be relocated.

NOTE: *When necessary to make side-to-side adjustments, loosen the radiator braces on models so equipped.*

When all bolts are loose, the sheet metal can shift to any desired position. It is not necessary to remove the hood, but the hood should be in the open position when sheet metal is shifted.

From this point, it is very important to secure the previously-loosened bolts in the following sequence:

Before any tightening is performed at this stage, it should have been determined whether the fender and door will have a parallel gap when set at the correct height at the rear. If correction is needed to make the gap parallel, the sheet metal must be raised or lowered at the chassis sheet metal mounts by adding or removing shims between the radiator support and the mount. Remember that the mount is compressed after tightening and will account for approximately 1/16" smaller gap on the bottom of the door opening than at the top.

1. Tighten the outer vertical fender to body attachment point first. Add or remove shims to position the fender vertically to door. Position the fender and door with a 7/32" (approximately) gap and flush to the door at the upper portion of fender to door.

Lower the hood gently to down position and check for squareness of the fender set. The hood should have parallel split lines with the fender, and the noses of the fenders parallel to the front end panel. If not in line, the sheet metal must be shifted sideways in the direction of the smaller gap until they are parallel. If only one fender has been loosened and much movement is necessary, the other fender must be loosened the same as the fender being reset; that is, all attachments except directly behind the hood hinge. The final position, if correct, will produce parallel hood-to-fender lines and a parallel condition to the front end panel. (See Figure 110-20 for causes of unparallel hood lines.)

Tighten the chassis sheet metal to frame bolts and torque to specifications. The sheet metal will not move once these four attachments (two fender to body at hood hinge and two sheet metal to frame) are tightened.

2. If the fender has poor alignment to upper portion of door, correcting may be made by loosening the two (2) vertical attachments of fender to upper cowl and one (1) attachment of fender to front of dash (rear of hood hinge); this will allow the upper portion of the door to be moved. If the lower portion of the fender must be realigned for flushness, the fender skirt bracket to body bracket located below steering column should be loosened, the vertical attachment of fender to body at the rear of the wheel opening, and the horizontal attachment of the rear lower portion of fender behind the door. Shims must be removed or added to flush the fender to door at this rear lower location.

3. All remaining bolts may now be tightened in any sequence.

If both fenders have been loosened, the other side should be attached using the same procedure.

b. Bumper Adjustment (Face Plate)

The bumper attaching bolt holes in the frame and the back bars are slotted to permit movement of the bumper and permit proper alignment with adjacent parts.

c. Hood Adjustment

1. Hood Set: First, the hood opening must have parallel gaps to front end panel and fenders to make a commercial job. Lower the hood gently to down position and determine the correct move to make fore and aft at the hood hinge to hood attachment. This is done by simply assuming the hinges aren't even there; that is, if the hood hangs forward on one side and back on the other, the hood is moved on the hinge to correct the misalignment at the nose. The parallel lines will fall in by themselves if the sheet metal is square. To align hood in an out-of-square opening, take a little out-of-parallel of the split lines and some misalignment at the front end panel. When the hood is moved fore or aft, on either side, it affects the hood and fender gap on all four corners of the hood. Therefore, don't make one move and spoil three others. The final adjusting is done by the hinge pillar attachment. Try for parallel lines but, as a last resort, you can move one fender outboard and the opposite inboard and pick up enough gap in the hood line to make a good job out of a poor one. Check door swing to hood if this is done.

2. Front Alignment for Flushness to Fender and Front End Panel: Three (3) adjustable bumpers are used for front end flushness. One is on the hood inner panel to the right of the hood latch opening, and one on each side of the upper tie bar. First lower the two (2) outer bumpers to allow the hood to fall below the fenders. Set the bumper in the hood panel to align the hood approximately 1/16 inch above the front end panel when the hood is lowered gently. The outer corners should now be approximately 1/8 inch low to fenders. If not, reform the nose of the hood to do so. Raise outer bumpers to flush hood to fender. This is done to put extreme pressure on outer corners and eliminate hood flutter. The center bumper only controls hood height at the center of the hood where hood is slammed.

3. Rear Vertical Alignment: If all component parts of fender mounting are correct, the hood hinge will pull the hood below the fender when the rear adjustable bumpers are lowered. If the rear of the hood does not fall low to the fenders, file the rear attaching hole of hinge to fender upward to bring the hood lower. Raise the rear adjustable bumper to flush hood to fender. This pressure on the rear hood bumpers is necessary to eliminate hood flutter. In cases of tight hood to fender split lines, the fender bumpers may hold the hood high to fender. Carefully flatten

bumper and surface until hood to fender split lines are even.

4. Hood Alignment: *Move hood to right or left at front by hinge adjustment.* Do not depend on the hood latch for hood alignment. The hood latch can, however, be adjusted sideways. If the hood latch is to be adjusted, care should be taken not to injure the mechanism. Always check the secondary latch by use of the release lever to insure absolutely no binding. The latch itself can be checked by closing the hood. Always check hood position in relation to the windshield wipers to be sure there is adequate clearance for wiper operation.

DIVISION IV

REMOVAL AND INSTALLATION

110-22 REMOVAL AND INSTALLATION OF HOOD ASSEMBLY

1. Support hood in extreme "up" position.
2. Place folded rags under rear corners of hood to prevent possible damage to fenders.
3. Scribe a reference line along edge of each hinge flange so hood can be replaced in same position.
4. Remove two hood hinge to hood bolts from each side.
5. Lift hood from car.
6. To install, reverse above procedure.

110-23 REMOVAL AND INSTALLATION OF HOOD HINGE SPRING

1. To remove hood hinge spring, insert Remover and Installer J-9214 through loop in forward end of spring with bend of tool approximately one inch from loop. Using inside corner formed by hinge as a pivot, unseat spring from notch.
2. Then push tool forward, causing hood spring to slide clear of hinge.
3. To replace hood spring, insert Remover and Installer J-9214 through loop in forward end of spring. Using hinge as a pivot, seat spring into notch.

110-24 REMOVAL AND INSTALLATION OF HOOD HINGE

a. Removal

1. Prop the hood in the extreme "up" position and place

folded rags under rear corners of hood to prevent possible damage to fenders.

2. Scribe position of the hood hinge on the hood and remove two hood hinge to hood bolts.

3. Scribe position of the hood hinge on the support. Remove the two bolts attaching the hinge to the support and remove the hinge.

b. Installation

1. Align hood hinge with scribe marks on support and install two bolts attaching the hinge to the support. Do not tighten.

2. Align hood hinge with scribe mark on hood and install two bolts attaching hood hinge to hood. Do not tighten.

3. Close hood and align flush with cowl and fenders.

4. Raise hood and tighten all mounting bolts to 25 lb.ft.

5. Remove all protective coverings.

110-25 REMOVAL AND INSTALLATION OF FENDER AND SKIRT

1. Disconnect battery cables and remove battery if battery is on same side as fender being removed.

2. Unfasten all electrical wires attached to fender skirt.

3. Remove three bolts securing battery base to radiator support and fender skirt. Lift out battery base.

4. Remove one bolt securing bracket to front bumper outer extension.

5. Remove cornering lamp if so equipped.

6. Remove two bolts securing lower portion of radiator support to lower front portion of fender.

7. Remove five bolts securing front of fender to radiator support.

8. Remove three screws securing fender lower front baffle.

9. Remove two hood hinge to fender bolts supporting hood as outlined in paragraph 110-24.

10. Remove two bolts securing skirt to lower portion of cowl.

11. Remove rocker panel moulding.

12. Remove two bolts securing lower rear edge of fender to rocker panel.

13. Remove one bolt securing upper rear portion of fender to bracket at hinge pillar. It is suggested that bracket not be removed from pillar.

14. Remove three bolts securing upper rear portion of fender to upper portion of cowl.

15. Remove two bolts securing fender to upper tie bar.

16. Raise up and lift off fender and skirt.

17. Skirt can now be removed from fender by removing skirt to fender attaching bolts.

18. To install, reverse above procedure attaching at points marked "Net" first.

SKETCHES SHOWING CAUSES OF UNPARALLELED HOOD LINES

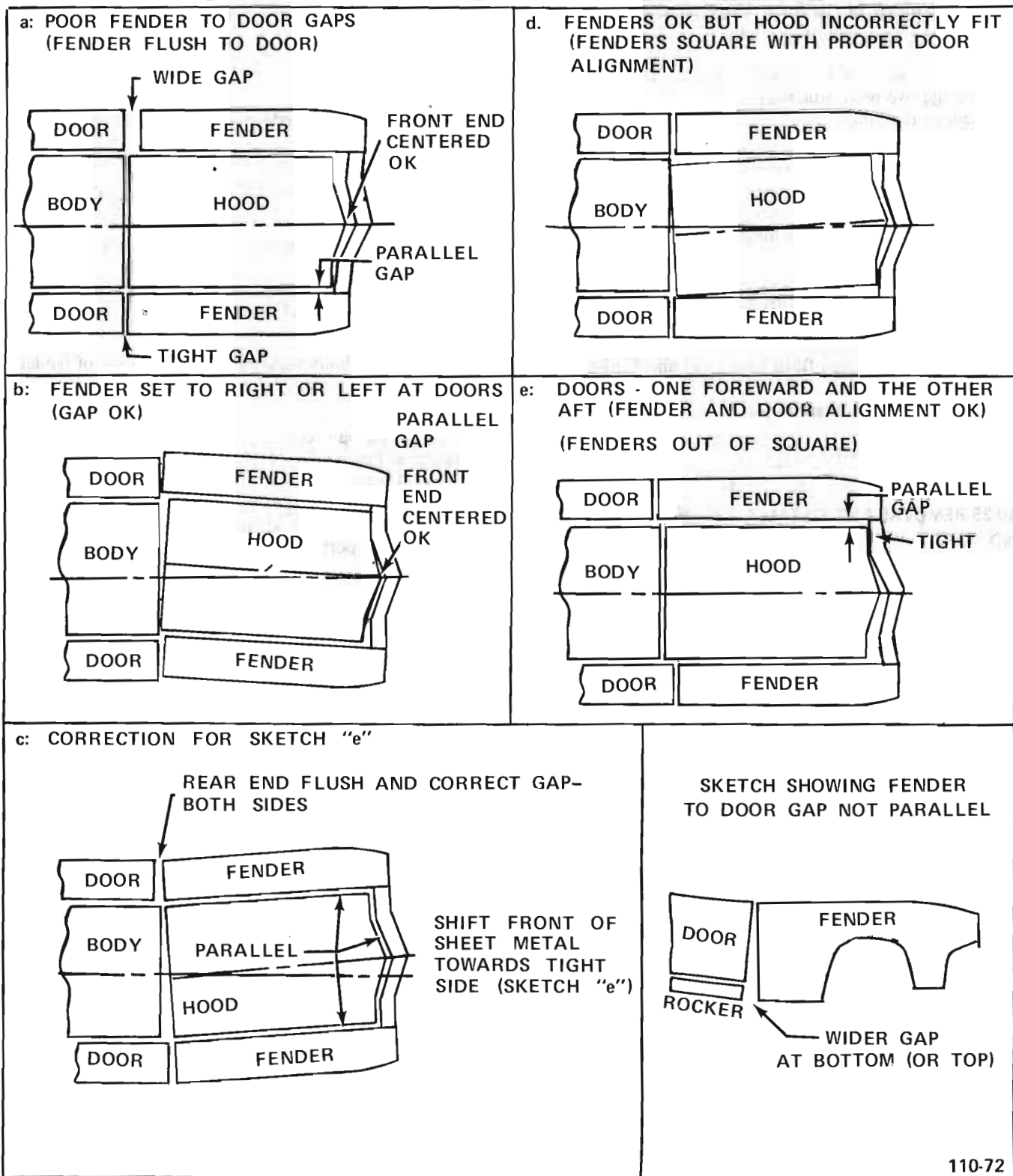

Figure 110-20 Chassis Sheet Metal Alignment

WHERE MINIMUM TORQUE ONLY IS SPECIFIED, FAILURE TORQUE IS AT LEAST 1/3 HIGHER.

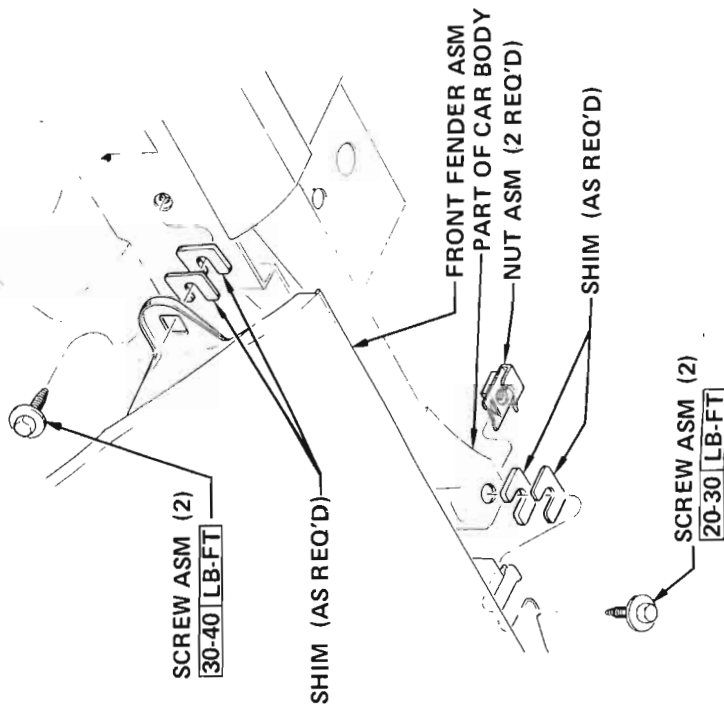
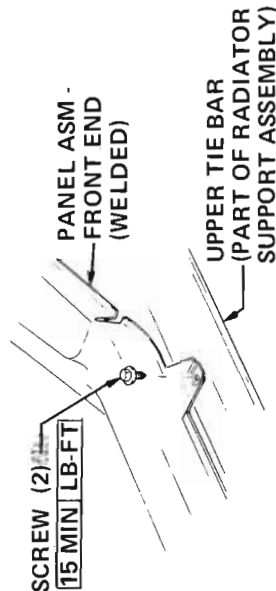
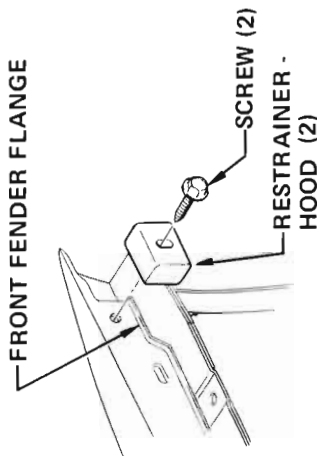
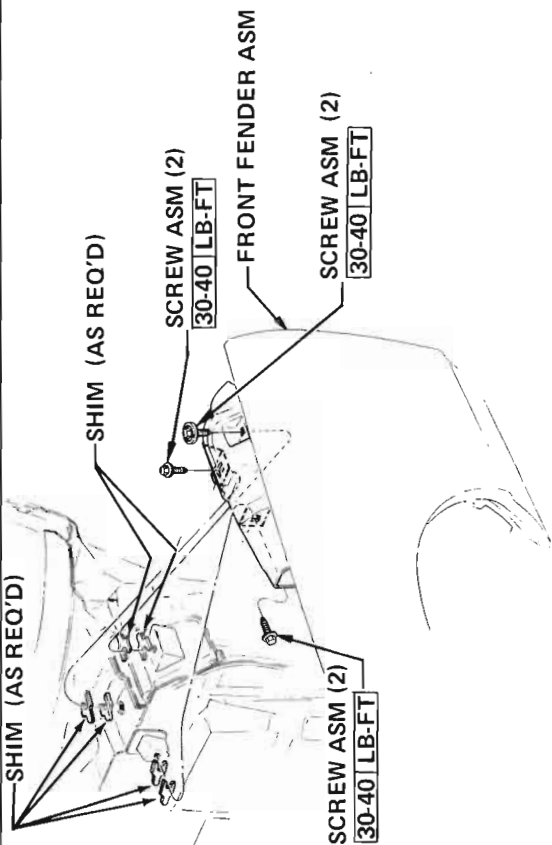
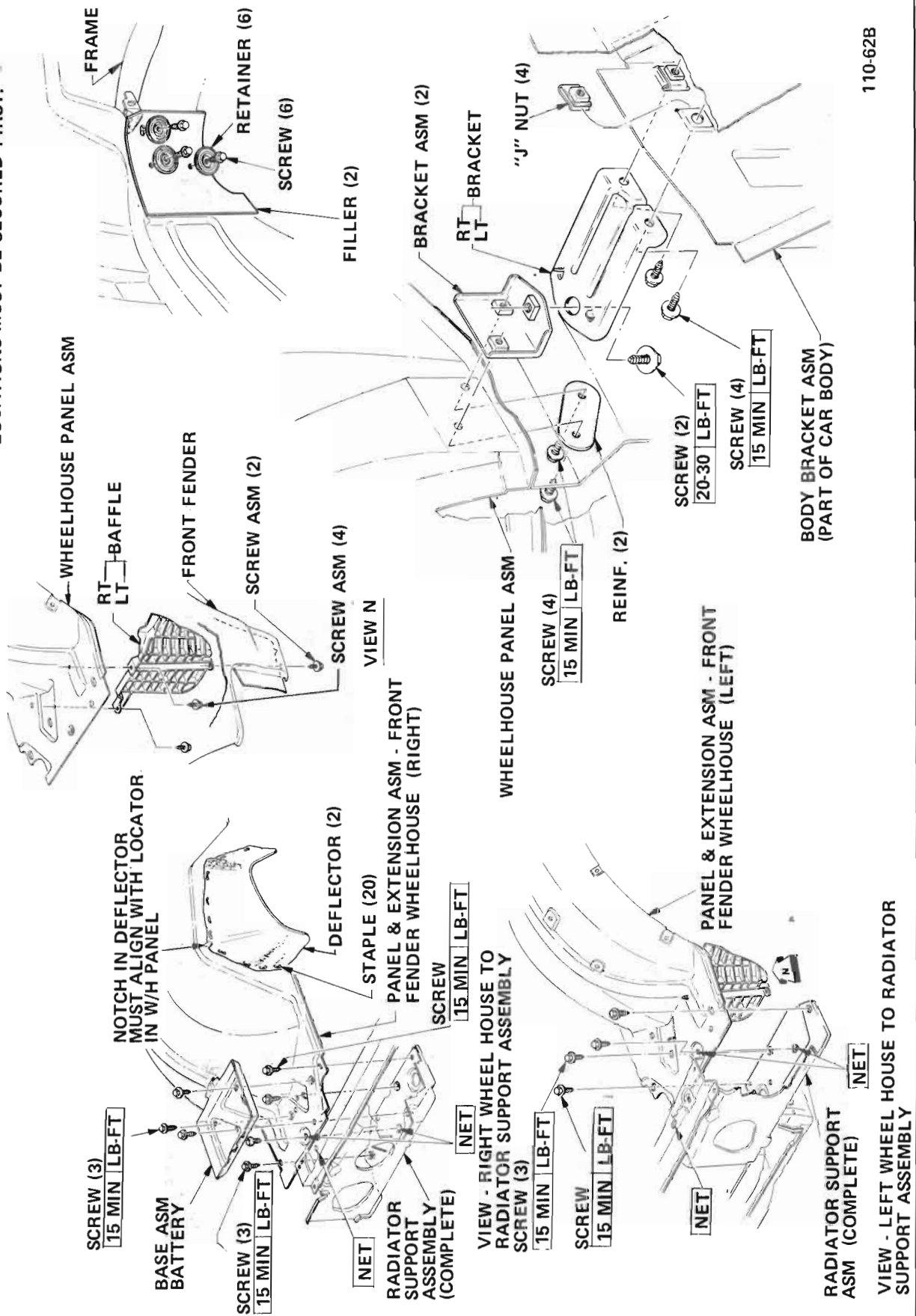

Figure 110-22 49000 Front Fender to Body

WHERE MINIMUM TORQUE ONLY IS SPECIFIED FAILURE TORQUE IS AT LEAST 1/3 HIGHER. HOLES SIGNALLED NET ARE FOR ASSEMBLY ALIGNMENT. ATTACHING PARTS AT THESE LOCATIONS MUST BE SECURED FIRST.



110-62B

Figure 110-23 49000 Wheelhouse Panels, Battery Base, and Baffle

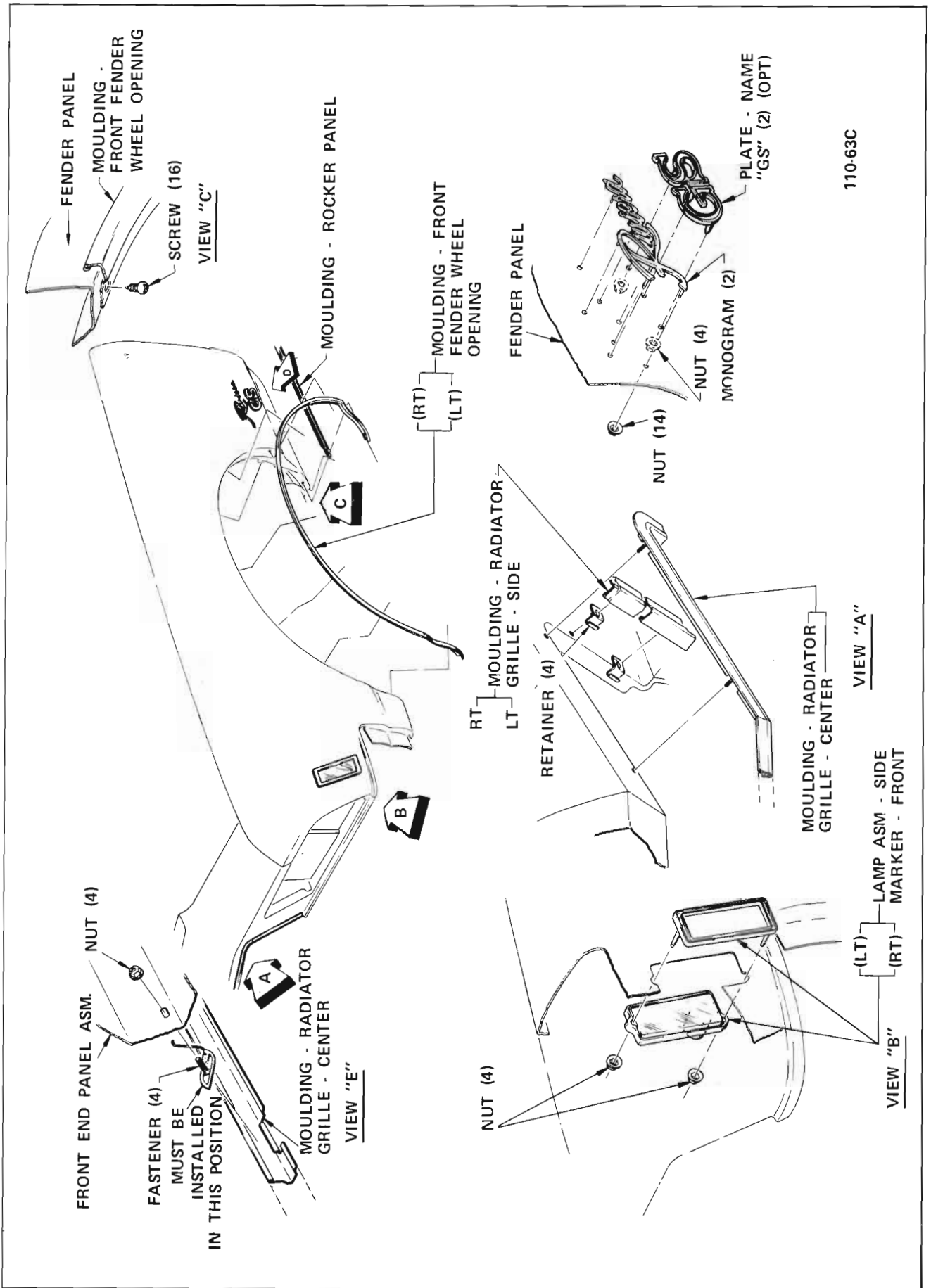

110-63C

Figure 110-24 49000 Front Fender Ornamentation

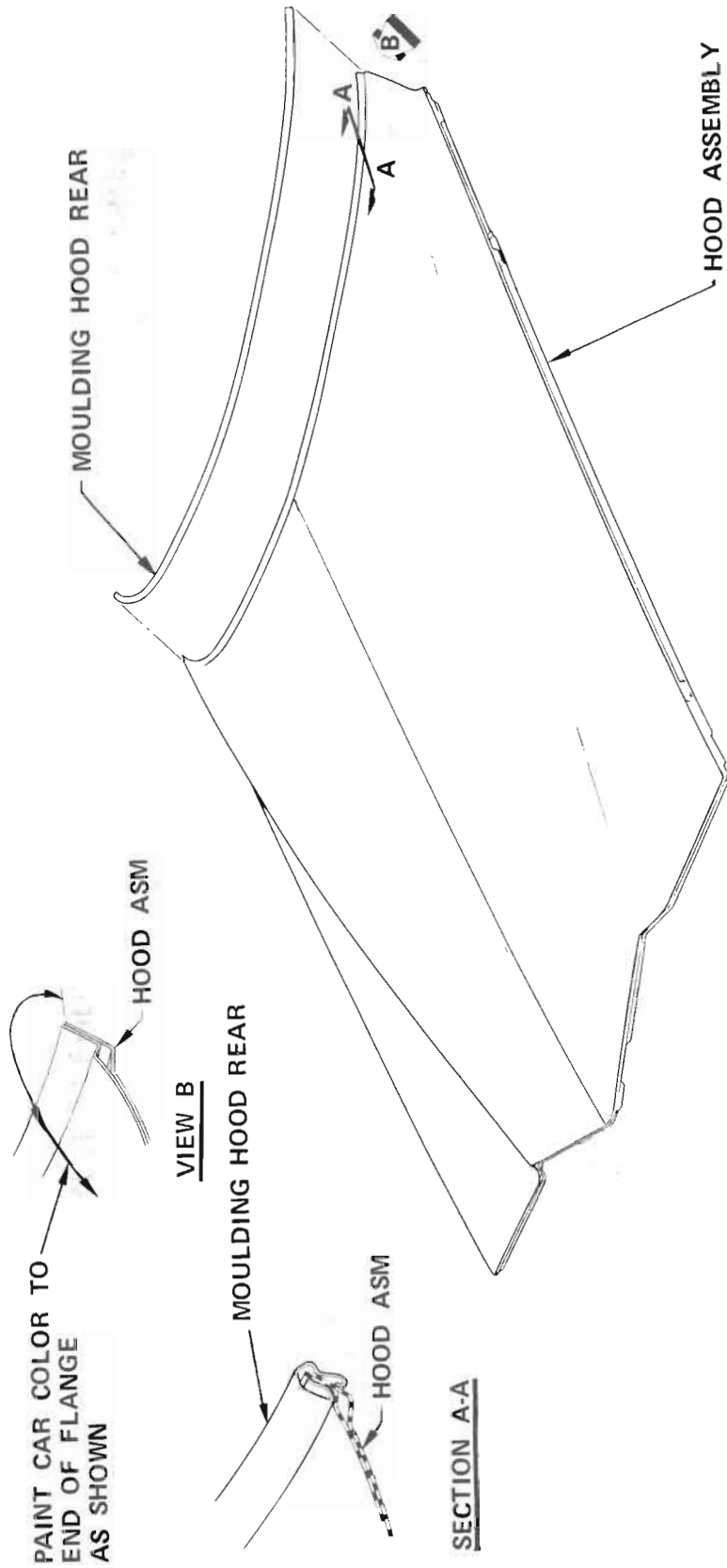

110-34F

Figure 110-25 49000 Hood Ornamentation

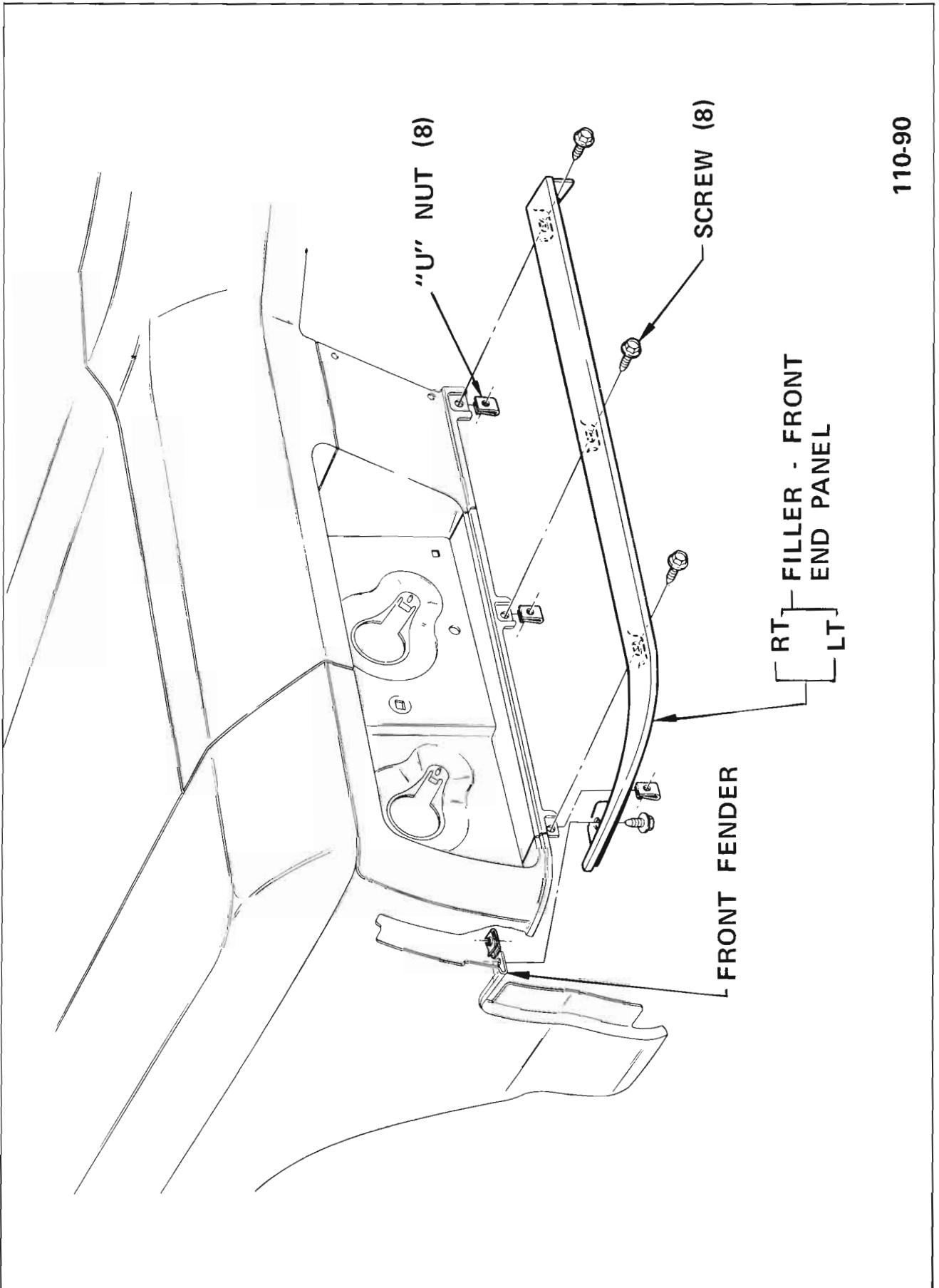

110-90

Figure 110-26 49000 Front End Panel Filler

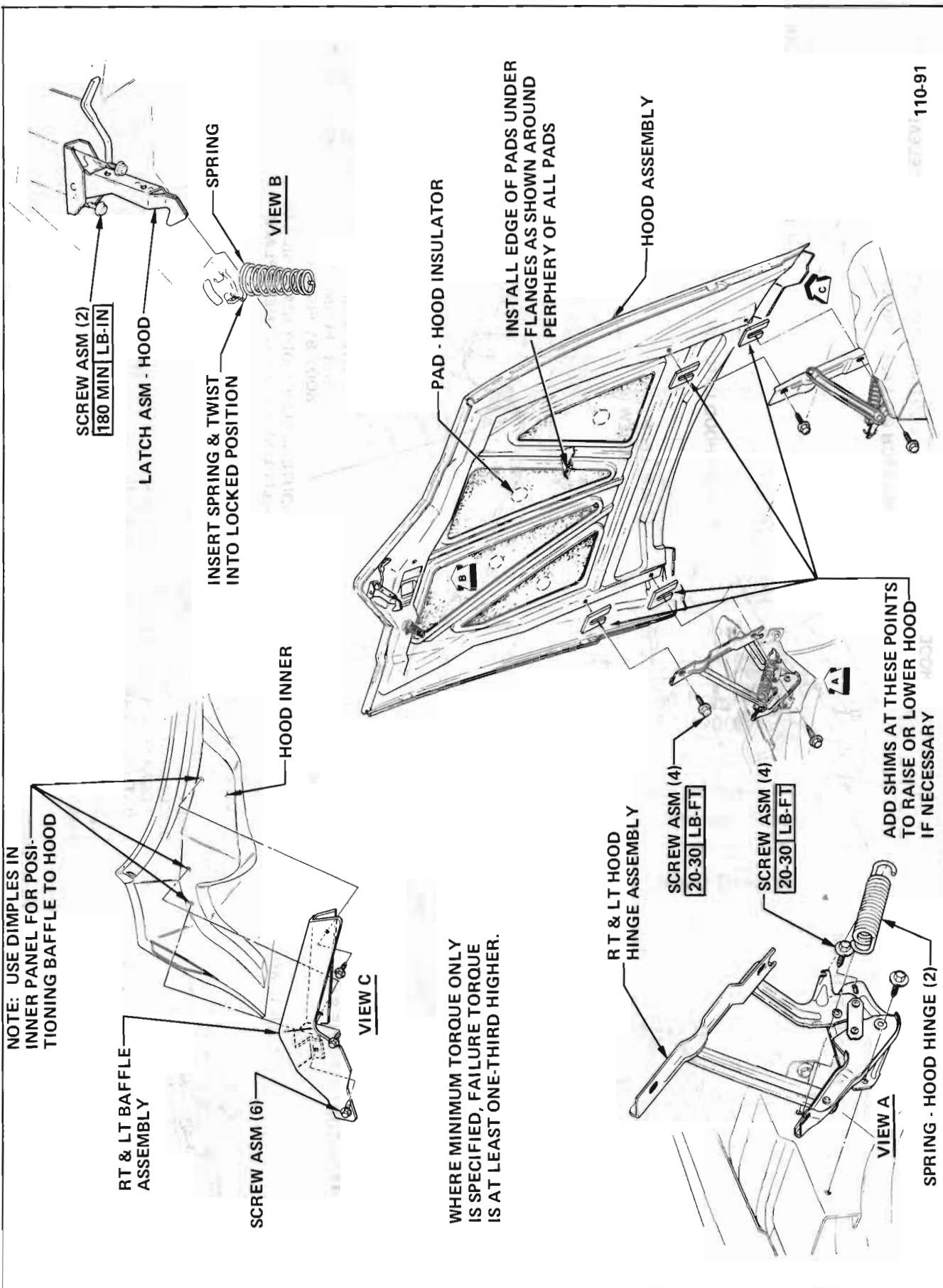
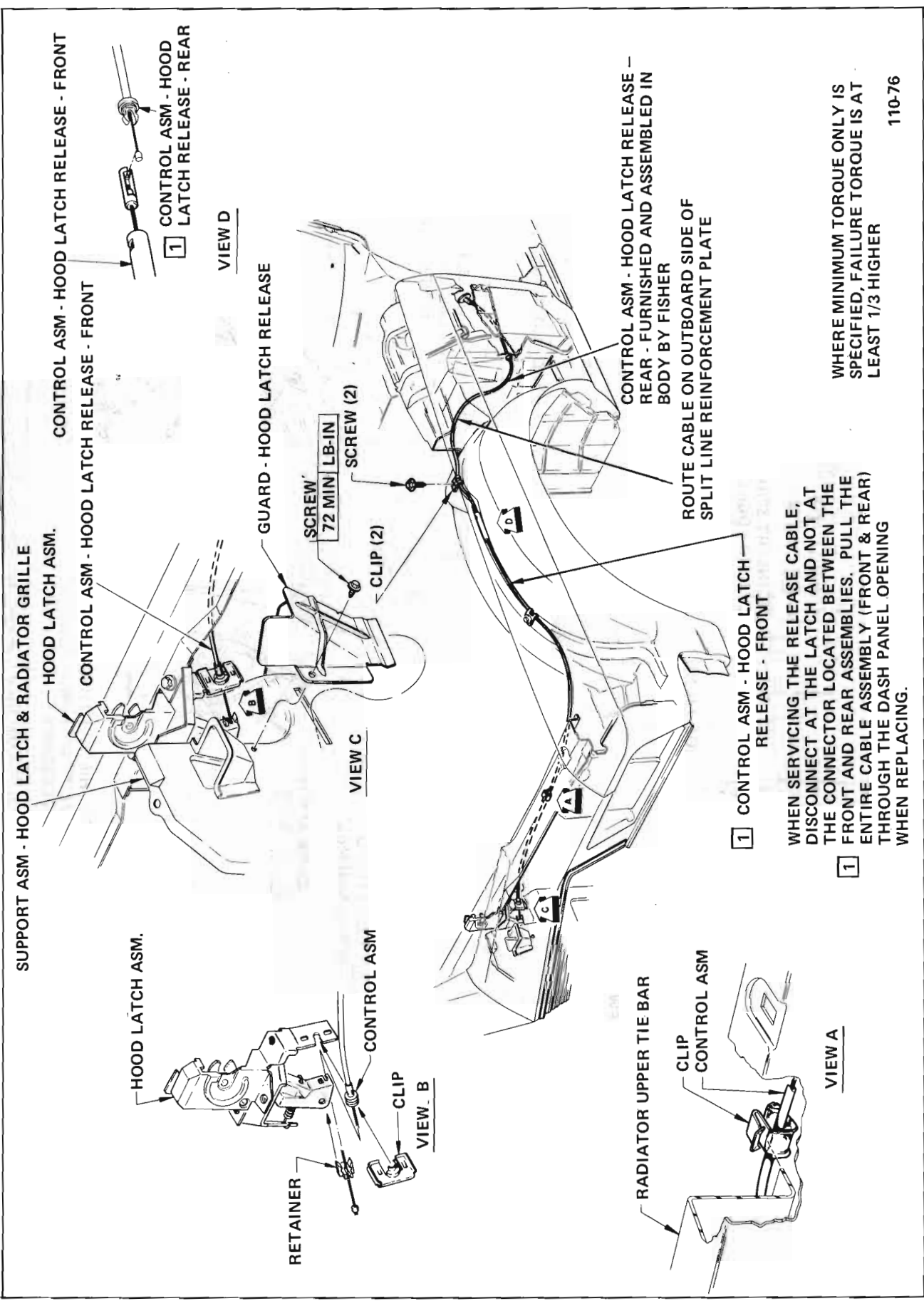

Figure 110-27 49000 Hood Assembly, Insulator, and Hinge



WHERE MINIMUM TORQUE ONLY IS SPECIFIED, FAILURE TORQUE IS AT LEAST 1/3 HIGHER

110-76

Figure 110-28 49000 Hood Latch Cable Routing and Hood Catch Guard