

SECTION E

ROCHESTER MV CARBURETOR

CONTENTS

Division	Subject	Paragraph
I	TROUBLE DIAGNOSIS: Model MV Diagnosis Chart.	64-29
II	DESCRIPTION AND OPERATION: Description and Operation of Rochester 1-Barrel Carburetor.	64-30
III	ADJUSTMENTS AND MINOR SERVICE: External Adjustments of Rochester 1-Barrel Carburetor.	64-31
IV	REMOVAL AND INSTALLATION: Rochester 1-Barrel Carburetor Removal and Installation Combined Emission Control Valve Removal and Installation.	64-32 64-33
V	OVERHAUL AND MAJOR SERVICE: Disassembly, Cleaning and Inspection of Rochester 1-Barrel Carburetor Assembly and Internal Adjustment of Rochester 1-Barrel Carburetor.	64-34 64-35
VI	SPECIFICATIONS: Rochester MV Carburetor Calibrations Rochester MV Carburetor Adjustments	64-36 64-37

DIVISION I

TROUBLE DIAGNOSIS

64-29 MODEL MV DIAGNOSIS CHART

CONDITION									CHECK POINTS	
HARD STARTING—COLD	HARD STARTING—HOT	POOR OPERATION—DURING WARM UP	STUMBLE ON ACCELERATION	STALLING	ROUGH IDLE	ECONOMY	FLOODING	SURGE	LACK OF HIGH SPEED PERFORMANCE	
1	1					1				<p>IMPORTANT</p> <p>Before attempting carburetor diagnosis as outlined below, all other engine systems must be operating properly. Diagnosis of these systems (electrical, exhaust, mechanical, and in the case of fuel economy, odometer accuracy) is found in this Service Manual. The numbers 1, 2 and 3, under the CONDITION are the order of probability. The * indicates additional possibilities.</p>
2		1			*	3			Driver Habits (Instruct Owner on Proper Procedures)	
*		*							Check Choke Parts Stuck, Dirty, Bound-Up or Gummed-Up	
*		*							Check Choke Rod Adjustment	
*	*	3			2	*			Check Choke Unloader Adjustment	
*			1						Check Choke Setting	
*			2						Check Accelerator Pump Rod Adjustment	
						*		*	2 Fuel Pump Pressure or Volume Not to Specification	
		2	*	1	1	*		*	Check C.E.C. Valve Adjustment	
								*	Fuel Tank Vent Plugged	
						*	1	*	Metering Jet Loose, Wrong Part or Rod Adjustment	
			*			4		3	3 Power Piston Sticking or Wrong Part	
	*						*		Float Sticking	
*	*				*	*	*	*	Float Bowl Porous, Cracked, Etc.	
	2				*	*	*	*	Check Float Level Adjustment	
*					*			*	Throttle Body to Float Bowl Screws Loose	
	*				*	*	2	2	Needle & Seat Dirty, Sticking, Loose	
	3		*		*	*		*	Check Pressure Relief Valve	
				2	3			*	Idle Passages Plugged, Dirty	
			*			*		*	Power Piston Vacuum Passage Plugged	
				3	*	*			Crankcase Vent Valve Plugged	
								*	Fuel Filter in Gas Tank Plugged	
							1	*	1 Fuel Filter in Carb. Plugged, By Passing Fuel	
						2		*	Air Cleaner or Element Plugged or Dirty	
								*	Hole in Fuel Pump Suction Line or Kinked Hose	
								*	No Full Throttle Opening at Carburetor	
	*	*	*			*			Check Heat Riser, Stuck Open or Closed	
*		*	3						Accelerator Pump Inoperative	
3		*							Check Vacuum Break Adjustment	

Figure 64-55 - Model MV Trouble Chart

DIVISION II

DESCRIPTION AND OPERATION

64-30 DESCRIPTION AND OPERATION OF ROCHESTER 1-BARREL CARBURETOR

a. General Description

The monojet carburetor used on the Buick, 6 cylinder engine is a single bore, down draft unit using a triple venturi in conjunction with a plain tube nozzle. The main venturi is 1 5/16" in diameter and the throttle bore is 1 11/16".

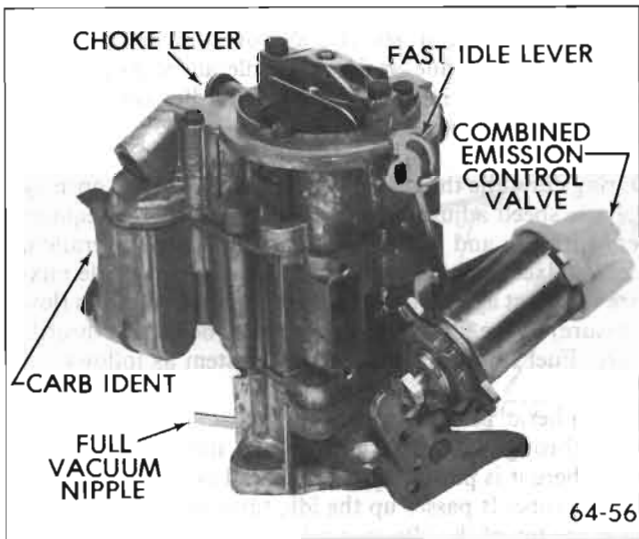

Figure 64-56 Rochester MV Monojet Carburetor

Fuel flow through the main metering system is controlled by a main well air bleed and a variable orifice jet. A power enrichment system is used to provide good performance during moderate-to-heavy acceleration and at higher engine speeds.

The idle system incorporates a hot idle compensator to maintain smooth engine idle during periods of extreme hot engine operation.

The monojet carburetor has an automatic choke system. The vacuum diaphragm unit is an integral part of the air horn. The choke coil is mounted on the manifold and is connected to the choke valve shaft by a rod.

An internal fuel inlet filter is mounted in the fuel bowl behind the fuel inlet nut to give maximum filtration of incoming fuel.

Other features of the monojet include an aluminum throttle body and a thick throttle body-to-bowl insulator gasket. The carburetor has internally balanced venting through a vent hole in the air horn which leads from the float bowl into the bore beneath the air cleaner. The float

bowl is externally vented through a pressure relief valve system which allows vapors to be vented during hot engine operation.

The carburetor part number is stamped on a vertical section of the float bowl, next to the fuel inlet nut. When replacing the float bowl assembly, follow the manufacturer's instructions contained in the service package so that the part number can be transferred to the new float bowl

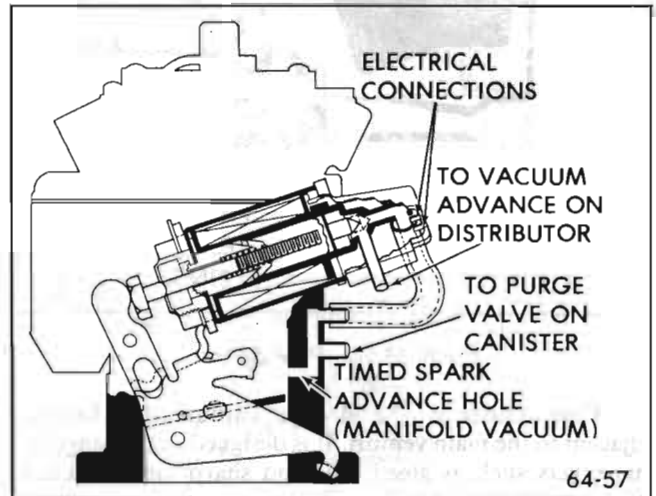

Figure 64-57 Combined Emission Control Valve

The idle stop solenoid has been replaced by a combination emission control valve (C.E.C. valve). See Figure 64-57. The valve, when energized through the transmission, acts as a throttle stop by increasing idle speed during high gear operations of the engine, which helps in controlling over-run hydrocarbons, during deceleration. The C.E.C. valve also provides full spark vacuum advance during high gear operation and is de-energized in the lower gears and at idle for retarded spark timing during this period. Normal idle speed setting will be made with the idle stop screw.

The idle mixture screw will have a limiter cap installed and no adjustment will be provided on the vehicle. The mixture screw will be preset at the factory and capped, and no further adjustment should be required except during cleaning and overhaul.

An overhaul idle mixture adjustment procedure will be provided, should the idle mixture needle need replacement or the mixture channels cleaned during the overhaul process. A new idle mixture needle limiter cap will be provided in the overhaul kit.

b. Operation of Float System

The float system controls the level of the fuel in the carburetor float bowl. Higher than specified fuel levels can cause flooding, hard hot starting and rich fuel mixtures causing poor economy, nozzle drip at idle, turn cut-out, rough idle and stalling.

Too low fuel levels can cause hard cold starting, hesitation, flatness on acceleration, and lean mixtures.

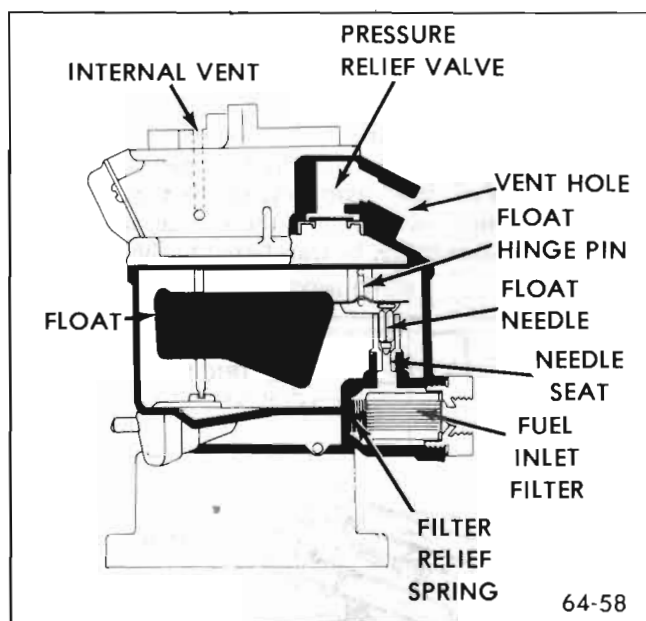

Figure 64-58 - Float System

The float system on the Monojet carburetor is located adjacent to the main venturi. It is designed so that angular maneuvers such as steep hills and sharp turns will not affect proper operation by keeping an adequate supply of fuel in the bowl at all times. The float system consists of the following: a fuel inlet filter and pressure relief spring, a solid single pontoon float made of special light weight plastic, a conventional needle and seat, and a float hinge pin. The float hinge pin fits in dual slots cast in the float bowl and is held in place by compression of the air horn gasket against the upper loop of the hinge pin. See Figure 64-58.

The float operates as follows. Fuel from the fuel pump is forced through the fibre fuel inlet filter located behind the fuel inlet nut. It passes from the filter up through the float needle seat and spills into the float bowl. As the float bowl fills with fuel it lifts the float pontoon upward until the correct fuel level is reached in the float bowl. At this point, the float arm forces the float needle against the float needle seat shutting off fuel flow. As fuel is used from the float bowl the float drops downward allowing the float needle to move off its seat and more fuel to enter the float bowl. This cycle continues throughout engine operation, keeping a nearly constant fuel level in the float bowl.

The fuel inlet filter has a pressure relief spring located at the rear of the filter. Should the filter become clogged from improper servicing or excessive amounts of dirt in the system, the relief spring lets the filter move off its seat. This prevents complete stoppage of fuel flow to the carburetor until the filter can be replaced.

The carburetor float chamber is both internally and externally vented. The internal vent channel is located in the air horn above the float chamber. The purpose of the internal vent is to balance air pressure on the fuel in the float bowl with carburetor inlet air. With this feature a

balanced air/fuel mixture ratio can be maintained during part throttle and power operation because the air pressure acting on the fuel in the float bowl will be balanced with the air flowing through the carburetor bore.

The Monojet carburetor has a pressure relief valve located at the top of the carburetor air horn. See Figure 64-58.

This allows fuel vapors which may form in the float bowl during hot engine idle and hot "soak" to be vented outside, so they will not be drawn into the engine manifold. This feature helps maintain a smooth engine idle and reduces hard hot starting.

c. Operation of Idle (Low Speed) System

The idle system consists of a removable idle tube, idle passages, idle channel restriction, idle air bleeds, slotted off-idle port, idle mixture adjusting needle, and the idle mixture discharge hole. See Figure 64-59.

During curb idle the throttle valve is held slightly open by the idle speed adjusting screw. Since the engine requires very little air and fuel for idle and low speed operation, fuel is mixed with the air to produce a combustible mixture by direct application of engine manifold vacuum (low pressure) to the idle discharge hole just below the throttle valve. Fuel flows through the idle system as follows.

Atmospheric pressure forces fuel from the float bowl down through the main metering jet into the main fuel well where it is picked up and metered at the lower tip of the idle tube. It passes up the idle tube and is mixed with air at the top of the idle channel through the idle air bleed hole. The air/fuel mixture passes over through the cross channel and then downward through the calibrated idle channel restriction where it is further metered. The mixture continues down the idle passage past the lower idle air bleed hole and off idle discharge port just above the throttle valve where it is again mixed with air. The air/fuel mixture then moves downward past the idle mixture needle and out through the idle discharge hole into the carburetor bore. Here it mixes with the air passing around the slightly open throttle valve to form a combustible mixture.

As the throttle valve is opened from curb idle to increase engine speed, additional fuel is needed to combine with the extra air entering the engine. This is accomplished by the slotted off idle port. As the throttle valve is opened, it passes the off idle port, gradually exposing it to high vacuum below the throttle valve. The additional fuel from the off idle port mixes with the increased air flow past the opening throttle valve to meet increased engine air and fuel demands. See Figure 64-59.

Further opening of the throttle valve causes increased air flow through the carburetor bore, which causes sufficient pressure drop in the multiple venturi to start fuel delivery from the main discharge nozzle. The off idle port fuel discharge does not cease at this transfer point, but diminishes as fuel flow from the main discharge nozzle in-

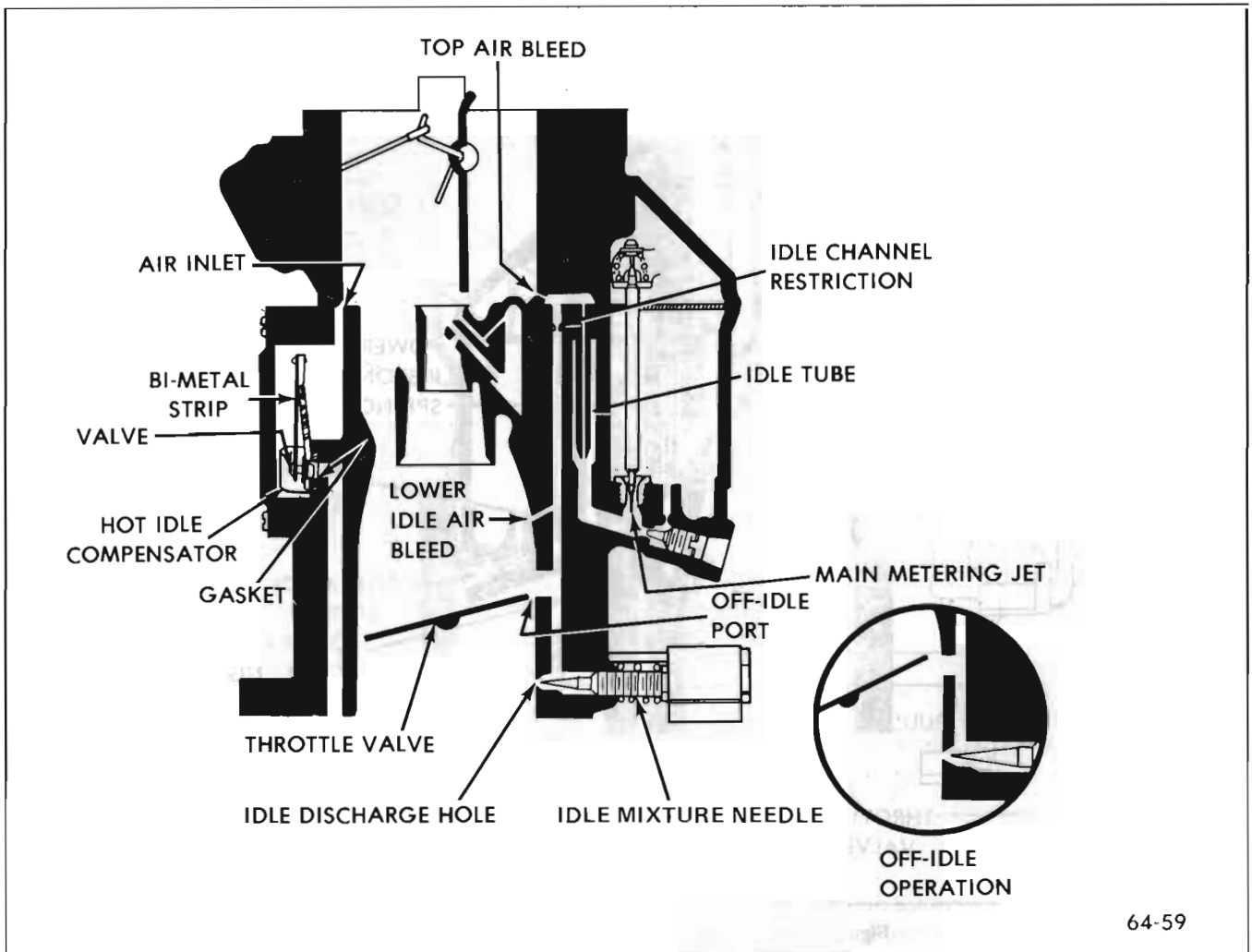

Figure 64-59 - Idle (Low Speed) System

creases. In this way, the systems are so designed that they combine to produce a smooth fuel flow at all engine speeds.

The lower idle air bleed is used strictly as an air bleed during idle operation. It supplies additional air to the idle circuit for improved atomization and fuel control at low engine speeds.

The same air bleed is used as an additional fuel feed at higher engine speeds, to supplement main discharge nozzle delivery, during operation of the main metering system.

The timed spark port has two tubes which supply vacuum during the off-idle and part throttle operation of the carburetor. One tube is connected by rubber hose to the C.E.C. valve to supply spark vacuum advance during high gear operation of the vehicle. The other tube leads to the purge valve on the vapor canister to provide a means of pulling greater amounts of fuel vapors from the canister during periods of higher air flow through the carburetor bore.

A limited amount of canister purge is also provided during idle operation by a separate channel in the vapor canister. Both purge systems are connected through the crankcase vent valve by a single hose leading from the vapor canister.

d. Operation of Main Metering (High Speed) System

The main metering system supplies fuel to the engine from off idle to wide open throttle operation. It feeds fuel at all times when air flow through the venturi is great enough to maintain fuel flow from the main discharge nozzle. See Figure 64-60.

The main metering system consists of a main metering jet, a mechanical and vacuum operated metering rod, main fuel well, main well air bleeds, fuel discharge nozzle and triple venturi.

The main metering system operates in the following manner: As the throttle valve is opened beyond the off idle range, air velocity increases in the carburetor venturi. This causes a drop in pressure in the main venturi which is increased many times in the smallest venturi.

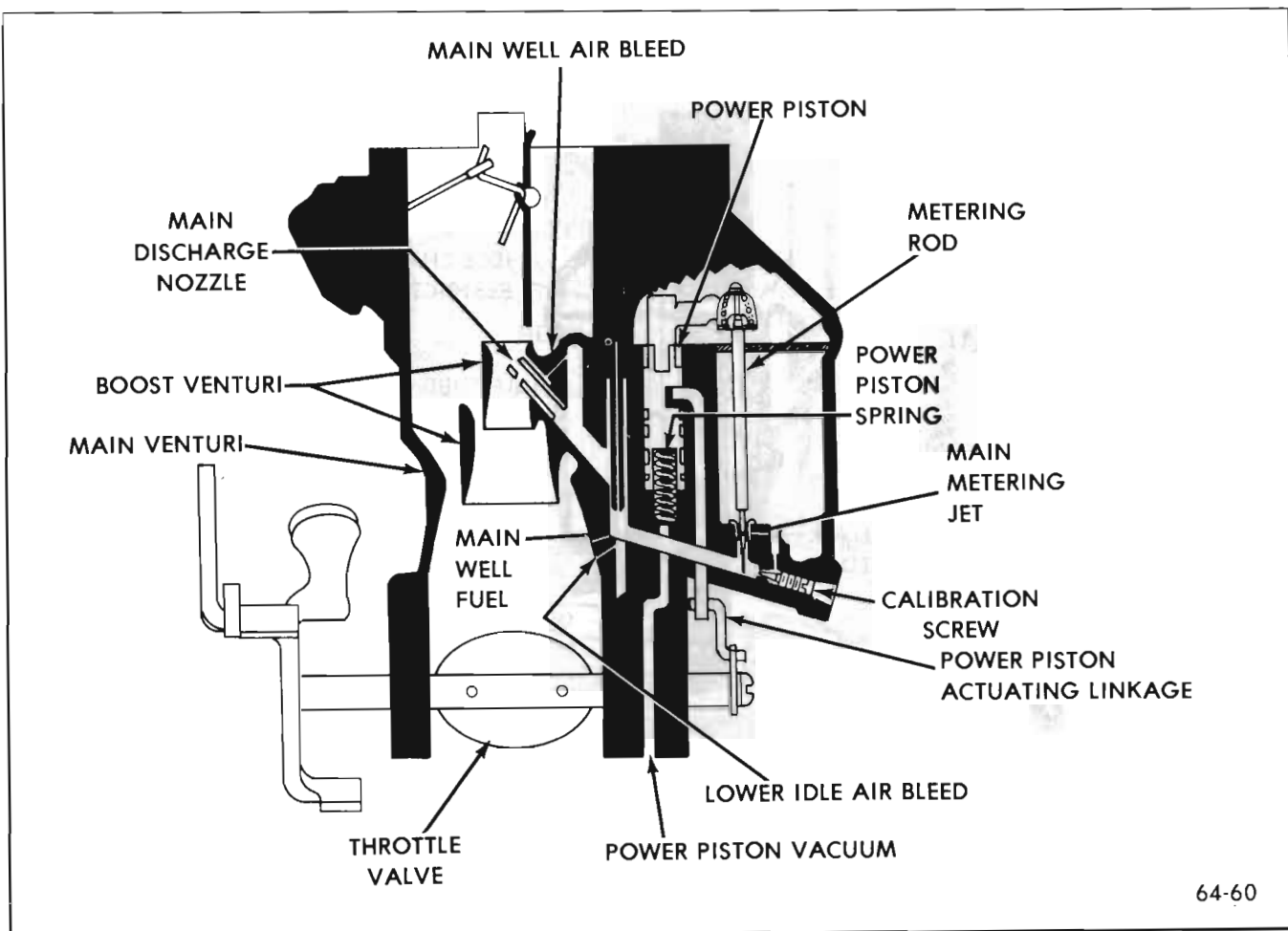

Figure 64-60 - Main Metering (High Speed) System

Fuel in the float bowl is metered between the tapered metering rod and the main metering jet. It then flows down into the main fuel well where it is mixed with air from the air bleed at the top of the well and another air bleed which leads into the main well from the discharge nozzle cavity. After the fuel in the main well is mixed with air from the air bleeds it then passes up the discharge nozzle where it sprays into the small boost venturi. At the boost venturi the fuel mixture then combines with air entering the engine through the carburetor bore to provide the correct air/fuel mixtures to the engine cylinders for efficient combustion.

Fuel flow to the main discharge nozzle is controlled by a tapered metering rod which is actuated by linkage connected directly to the throttle shaft. As the throttle valve is opened from idle position, the tapered metering rod is gradually raised out of the main metering jet orifice. With the fuel metering mechanically controlled by the throttle valve angle, it is possible to maintain very accurate mixture ratios throughout part throttle to wide open throttle operation.

An initial metering rod adjustment is required to set the depth of the rod in the main metering jet.

CAUTION: *It should be noted here that there is a supplementary fuel feed passage in the bottom of the float bowl adjacent to the main metering jet. Fuel is picked up from the float bowl and passes through a calibrated hole past a calibration screw and on into the same fuel passage which leads from the main metering jet to the main fuel well. The purpose of the adjustable fuel feed is to allow production to refine part throttle calibration to meet very accurate air/fuel mixture ratios. The factory adjustment is made using very sensitive instrumentation and the screw should not be readjusted in the field. If the adjustment is tampered with, it will require complete float bowl or unit replacement.*

e. Operation of Power System

The vacuum operated enrichment system in the Monojet carburetor is used to slightly enrich mixture ratios during operation with moderate to heavy loads. The necessary enrichment is obtained by movement of a spring loaded vacuum piston which senses changes in manifold vacuum. The amount of enrichment is controlled by the clearance between the groove in the power piston and the diameter of the power piston drive rod. See Figure 64-61.

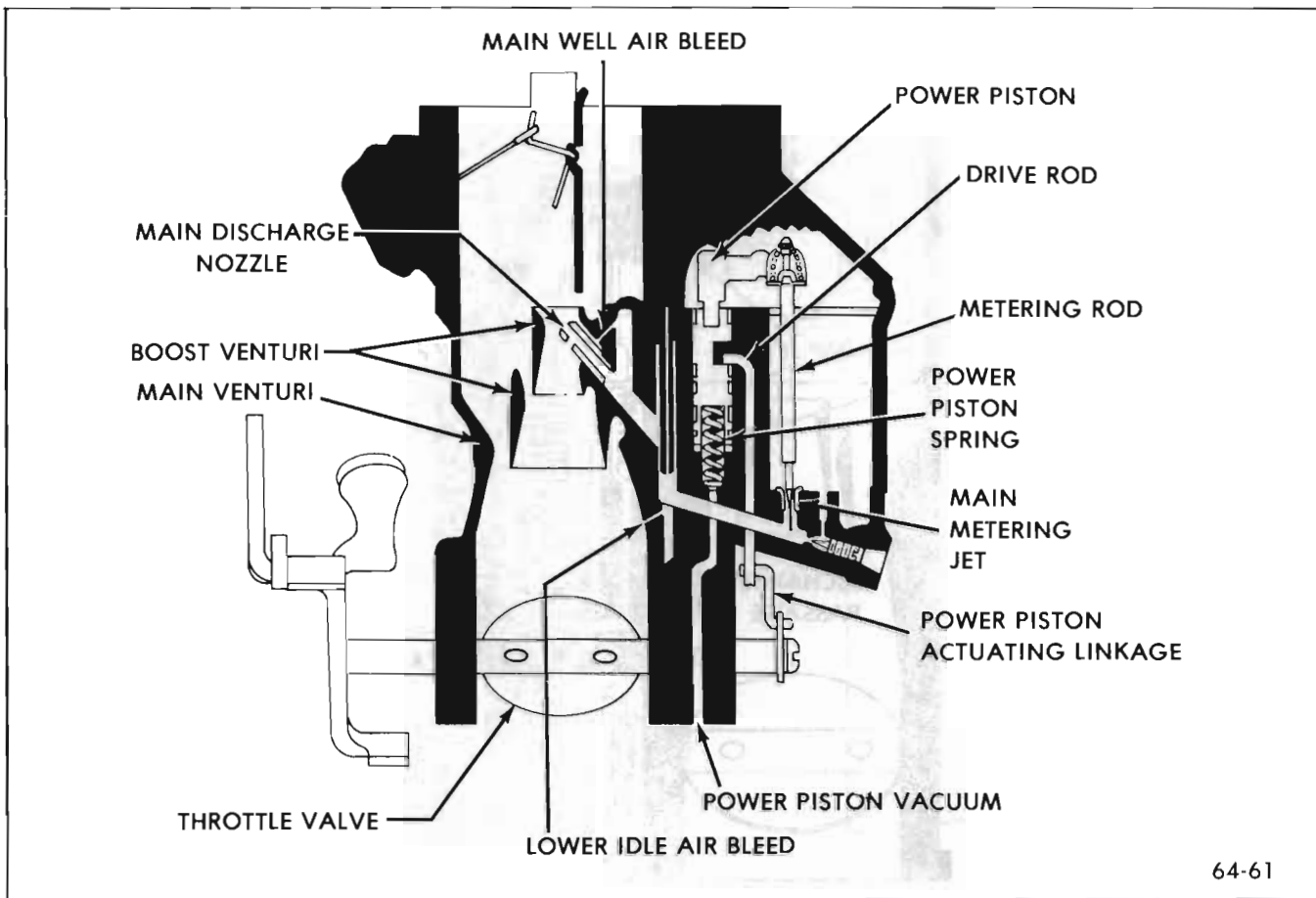

64-61

Figure 64-61 - Power System

During part throttle and cruising ranges, manifold vacuum is sufficient to hold the power piston down against spring tension. The upper part of the groove in the power piston is held down against the top side of the drive rod. This places the main metering rod lower in the jet for maximum economy. On moderate to heavy accelerations, manifold vacuum drops and the power piston spring pushes the power piston up so that the lower edge of the slot in the power piston strikes the bottom side of the drive rod. This moves the tapered metering rod slightly upward in the jet. This allows more fuel to flow through the jet, enriching the fuel mixture slightly.

e The amount of enrichment is controlled by the amount of clearance between the groove in the side of the power piston and the diameter of the drive rod. This clearance is factory calibrated to match the fuel enrichment requirements of a given engine.

f. Operation of Accelerating Pump System

Rapid opening of the throttle valve, when accelerating from low speed, causes an immediate increase in air flow through the carburetor bore. Since fuel is heavier than air, it requires a short period of time for fuel flow through the main discharge nozzle to "catch up" with the flow. To avoid leanness during this momentary lag in fuel flow, the accelerator pump furnishes a metered quantity of fuel

which is sprayed into the air stream. This mixes with the increased air flow, to supply the extra fuel needed, until the main discharge nozzles can feed the fuel required.

The accelerating pump is located at the side of the main fuel bowl. It consists of a spring loaded pump plunger and pump return spring operating in a fuel well. The pump plunger is connected by linkage directly to a lever on the throttle shaft. See Figure 64-62.

When the pump plunger moves upward in the pump well, fuel from the float bowl enters the pump well through a slot in the side of the pump well. It flows past the synthetic pump cup seal into the bottom of the pump well. The pump cup is a floating type. (The cup moves up and down on the pump plunger head). When the pump plunger is moved upward, the flat on the top of the cup unseats from the flat on the plunger head and allows free movement of fuel through the inside of the cup into the bottom of the pump well. This also vents any vapors which may be in the pump well so that a solid charge of fuel can be maintained in the fuel well beneath the plunger head.

When the throttle valve is opened, the connecting pump linkage forces the pump plunger downward. The pump cup seats instantly and fuel is forced through the pump discharge passage, where it unseats the pump discharge check ball and passes on to the pump jet, where it sprays into the boost venturi area.

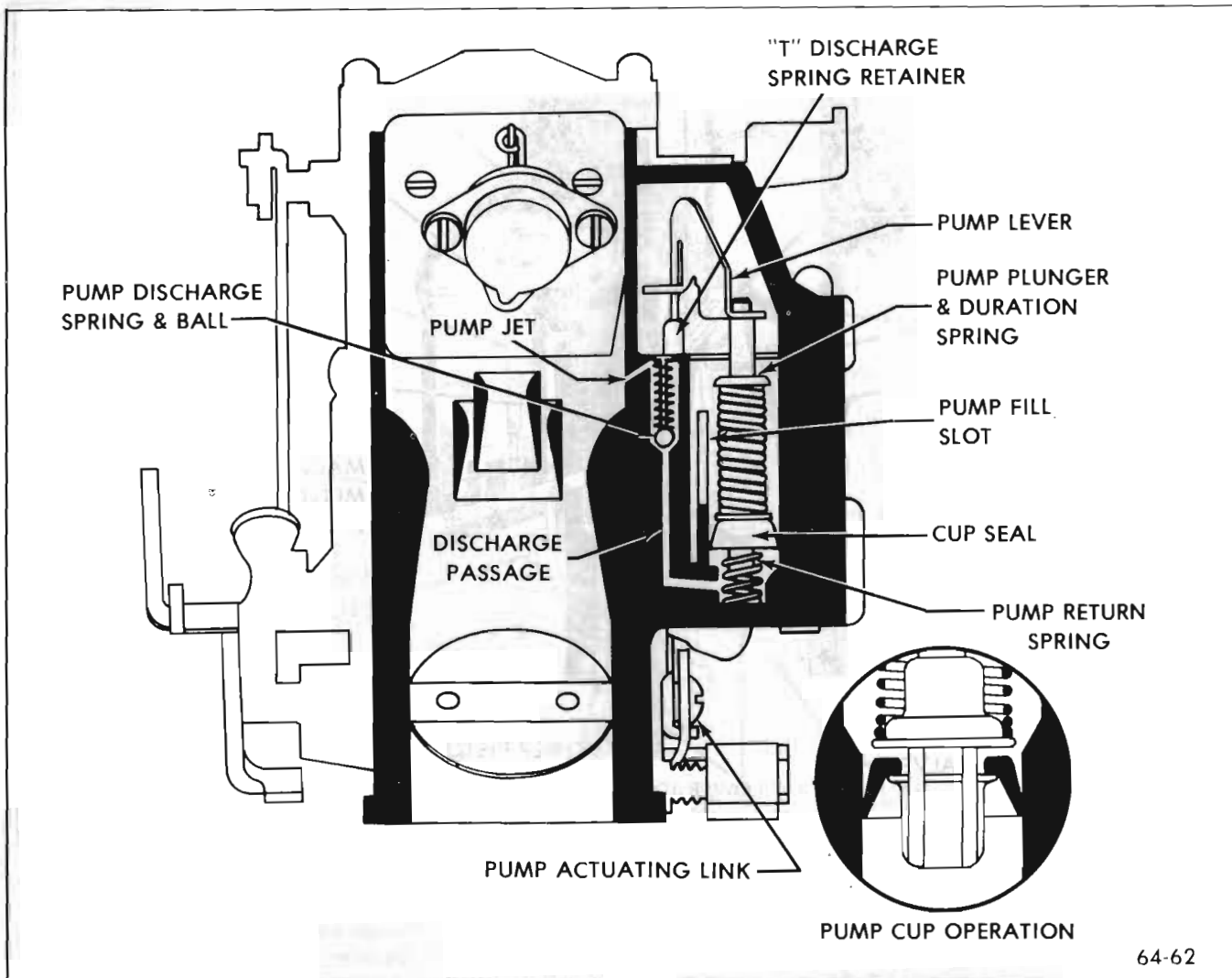

64-62

Figure 64-62 - Accelerating Pump System

It should be noted the pump plunger is spring loaded. The upper duration spring is balanced with the bottom pump return spring so that a smooth sustained charge of fuel is delivered during acceleration.

The pump discharge check ball prevents any "pull over" or discharge of fuel from the pump jet when the accelerator pump is not in operation. It also keeps the pump discharge passage filled with fuel to prevent pump discharge lag.

The pump plunger does not require adjustment in the field as it is preset during manufacture.

g. Operation of Choke System

The purpose of the choke system is to provide a richer mixture for cold engine starting and operation. Richer than normal mixtures are required because vaporized fuel has a tendency to condense on cold engine parts, thereby decreasing the amount of combustible mixture available in the engine cylinders.

The Model MV carburetor is equipped with a fully automatic choke control. The thermostatic coil is mounted on the engine manifold and is connected by a link to the lever on the choke valve shaft. The vacuum break unit is diaphragm operated and is part of the air horn casting. See Figure 64-63.

The Model MV choke system operates as follows. When the engine is cold, prior to starting, depressing the accelerator pedal opens the carburetor throttle valve. This allows tension from the thermostatic coil to close the choke valve. This also rotates the fast idle cam so the fast idle tang comes to rest on the high step of the fast idle cam. This provides enough throttle valve opening to keep the engine running after a cold start. During cranking, engine vacuum below the choke valve pulls fuel from the idle circuit and main discharge nozzle. This provides adequate enrichment from the fuel circuits for good cold starts.

When the engine starts, manifold vacuum is transmitted through a vacuum channel to the vacuum break diaphragm unit. This moves the diaphragm plunger until it strikes the cover, which in turn, opens the choke valve to

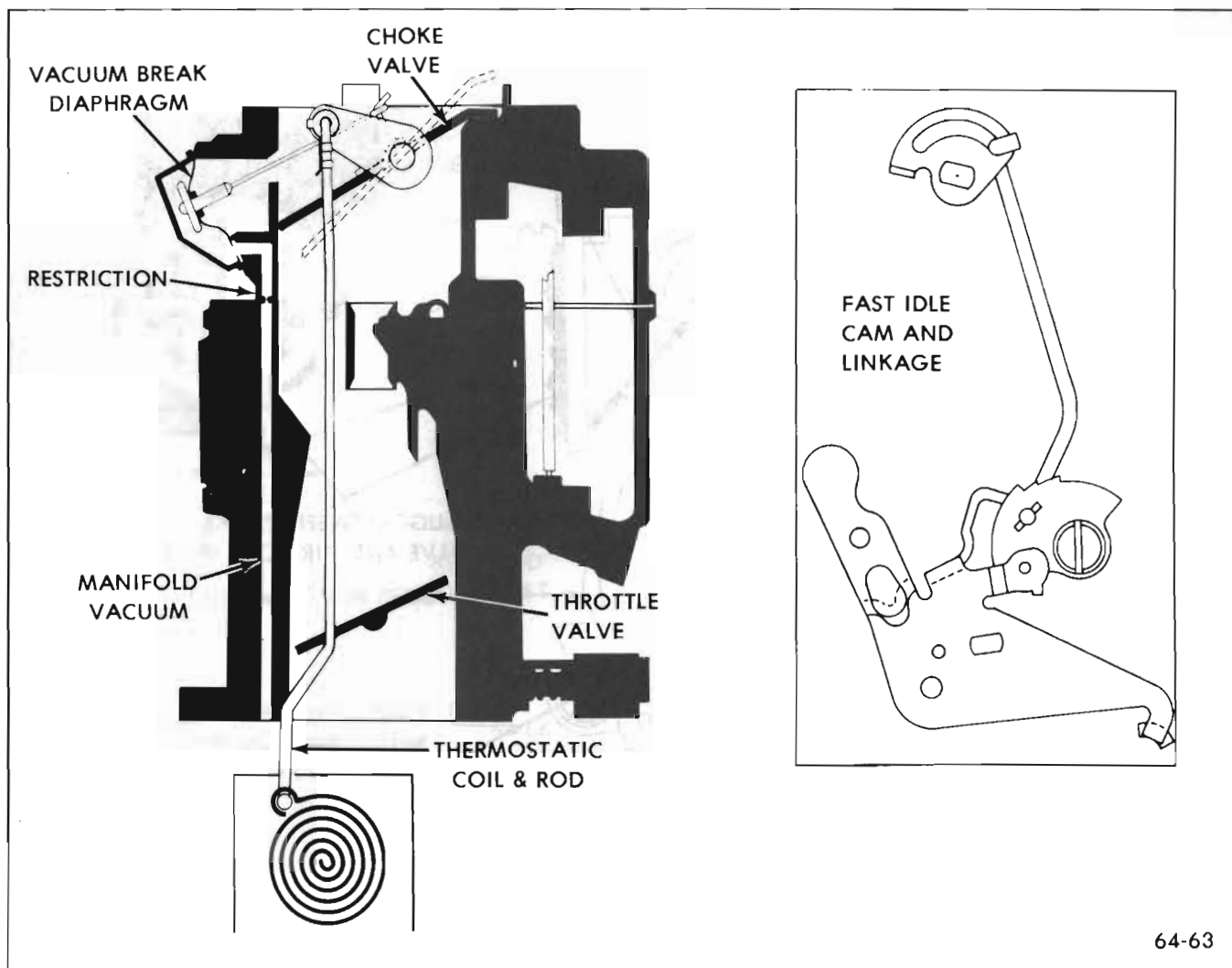

64-63

Figure 64-63 - Choke System

a point where the engine runs without loading or stalling. This is called the vacuum break position.

As the engine warms up the thermostatic coil is heated and gradually relaxes its spring tension so that air velocity through the air horn can continue to open the choke valve. This continues until the engine is warm. At this point the choke coil tension is completely relaxed and the choke valve is wide open.

The fast idle cam has graduated steps so that fast idle engine speed is lowered gradually during the engine warm up period. The fast idle cam follows rotation of the choke valve. When the choke valve is completely open and the engine is warm, the fast idle tang on the throttle lever will be off the steps of the fast idle cam. At this point, the idle screw controls normal engine idle speed.

An unloader mechanism is provided should the engine become flooded during the starting period. The unloader partially opens the closed choke valve to allow increased air flow through the carburetor to lean out the overly rich mixtures. This is accomplished by depressing the accelera-

tor pedal to the floor so that wide open throttle is obtained. When this is done a tang on the throttle lever contacts an arm on the fast idle cam and forces the choke valve partially open. The extra air leans out the fuel mixture enough so that the engine will start.

DIVISION III

ADJUSTMENTS AND MINOR SERVICE

64-31 EXTERNAL ADJUSTMENT OF ROCHESTER 1-BARREL CARBURETOR

a. Fast Idle Adjustment

The fast idle adjustment on the momojet carburetor is pre-set by the manufacturer and does not need any further adjustment.

b. Choke Rod Adjustment

With fast idle adjustment made first:

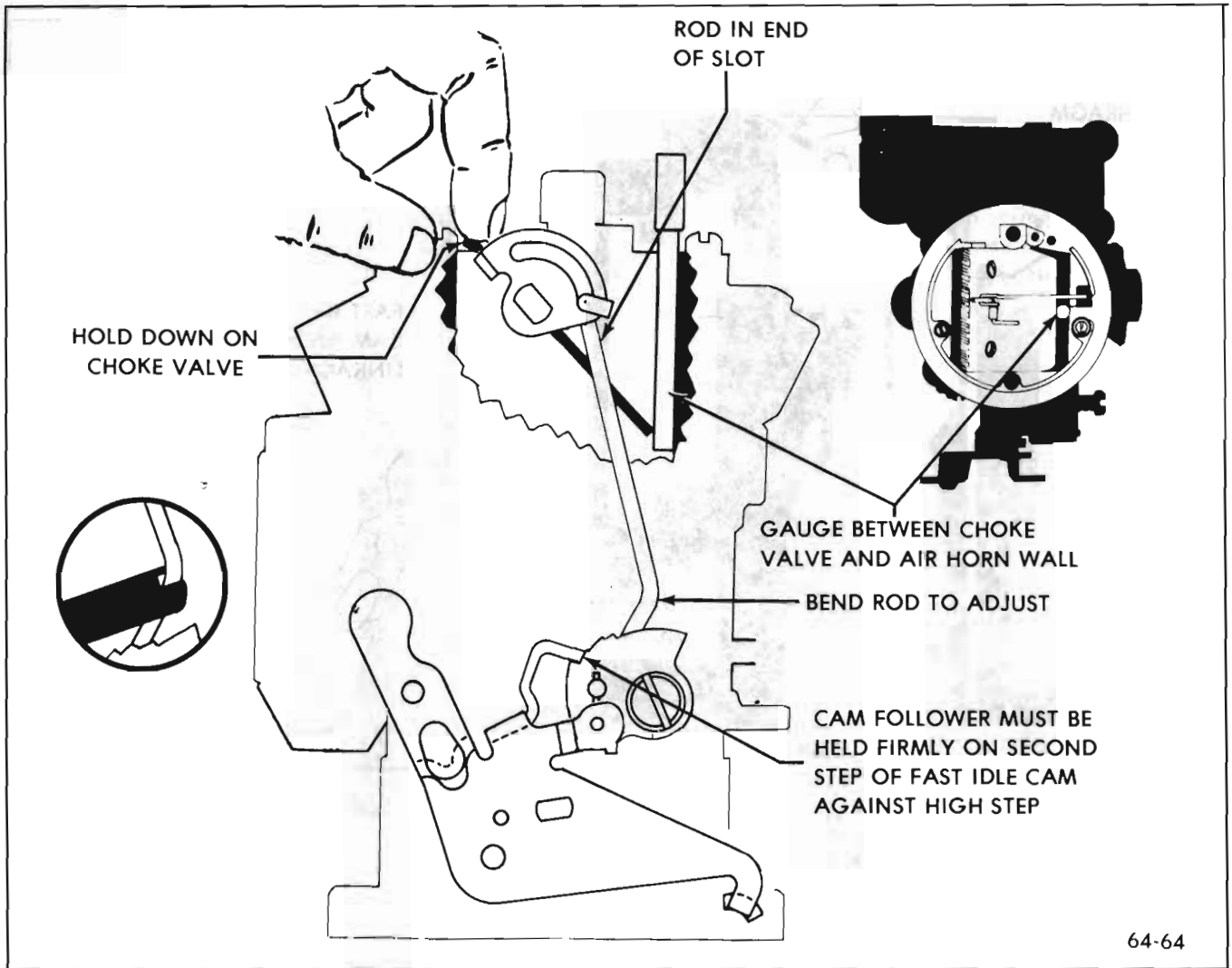

64-64

Figure 64-64 Choke Rod Adjustment

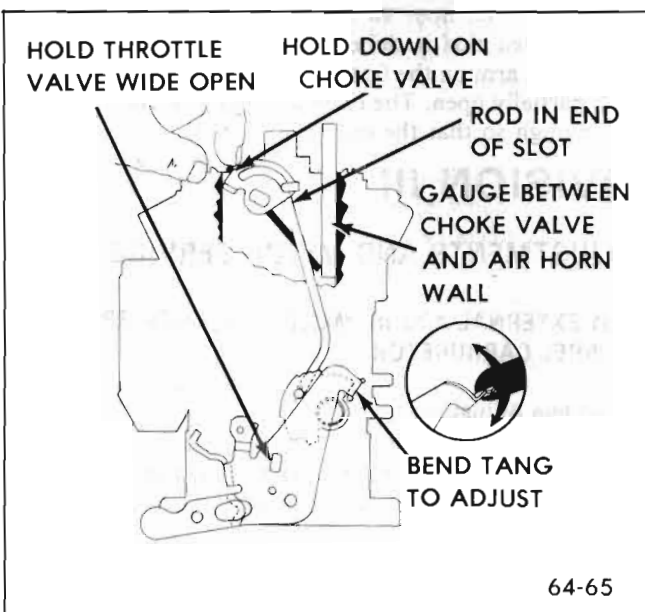

64-65

Figure 64-65 Choke Unloader Adjustment

1. Place fast idle cam follower on second highest step of fast idle cam and hold firmly against rise to high step. See Figure 64-64.

2. Rotate choke valve toward direction of closed choke by applying force to choke coil lever.

3. Bend choke rod at point shown to give specified opening between the lower edge of choke valve (at center of valve) and air horn wall.

d. Choke Unloader Adjustment

1. Hold choke valve toward closed position by applying a light force to choke coil lever.

2. Rotate throttle lever to wide open throttle valve position.

3. Bend unloader tang on throttle lever to obtain .350 inch dimension between lower edge of choke valve and air horn wall. See Figure 64-66.

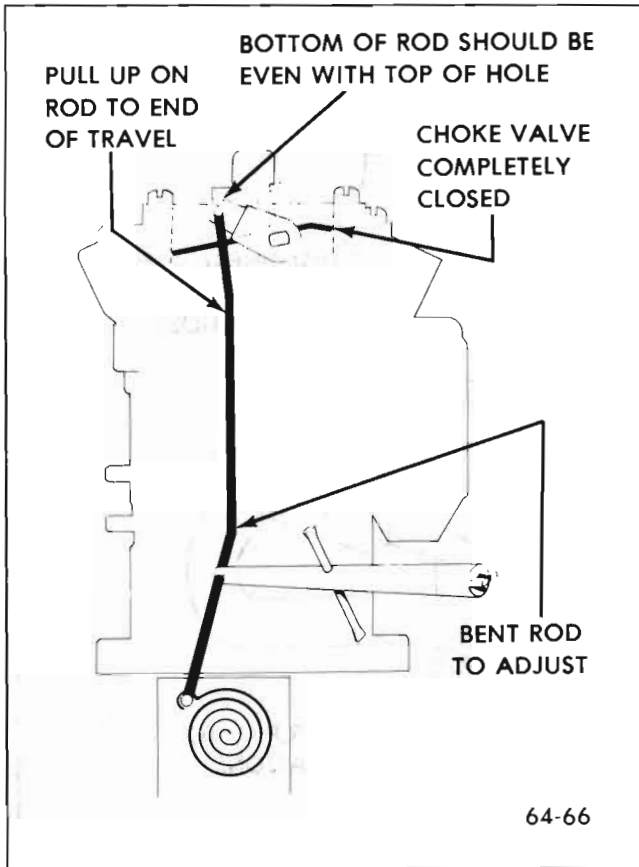

e. Choke Coil Rod Adjustment

1. Hold choke valve closed.
2. Pull upward on thermostatic coil rod to end of travel.
3. With the thermostatic coil rod disconnected, the bottom of rod should be even with the top of hole in lever. In other words, the rod should have one diameter interference or tension to hold the choke valve closed.

f. Vacuum Break Adjustment

1. Rotate choke valve to closed position.
2. Hold choke valve closed with rubber band attached between choke shaft lever and stationary part of carburetor as shown.
3. Grasp vacuum break plunger rod with needle nose pliers and push straight inward until diaphragm seats. See Figure 64-67.
4. With specified plug gage, measure clearance between lower edge of choke valve and inside air horn wall.

◀ Figure 64-66 Choke Coil Rod Adjustment

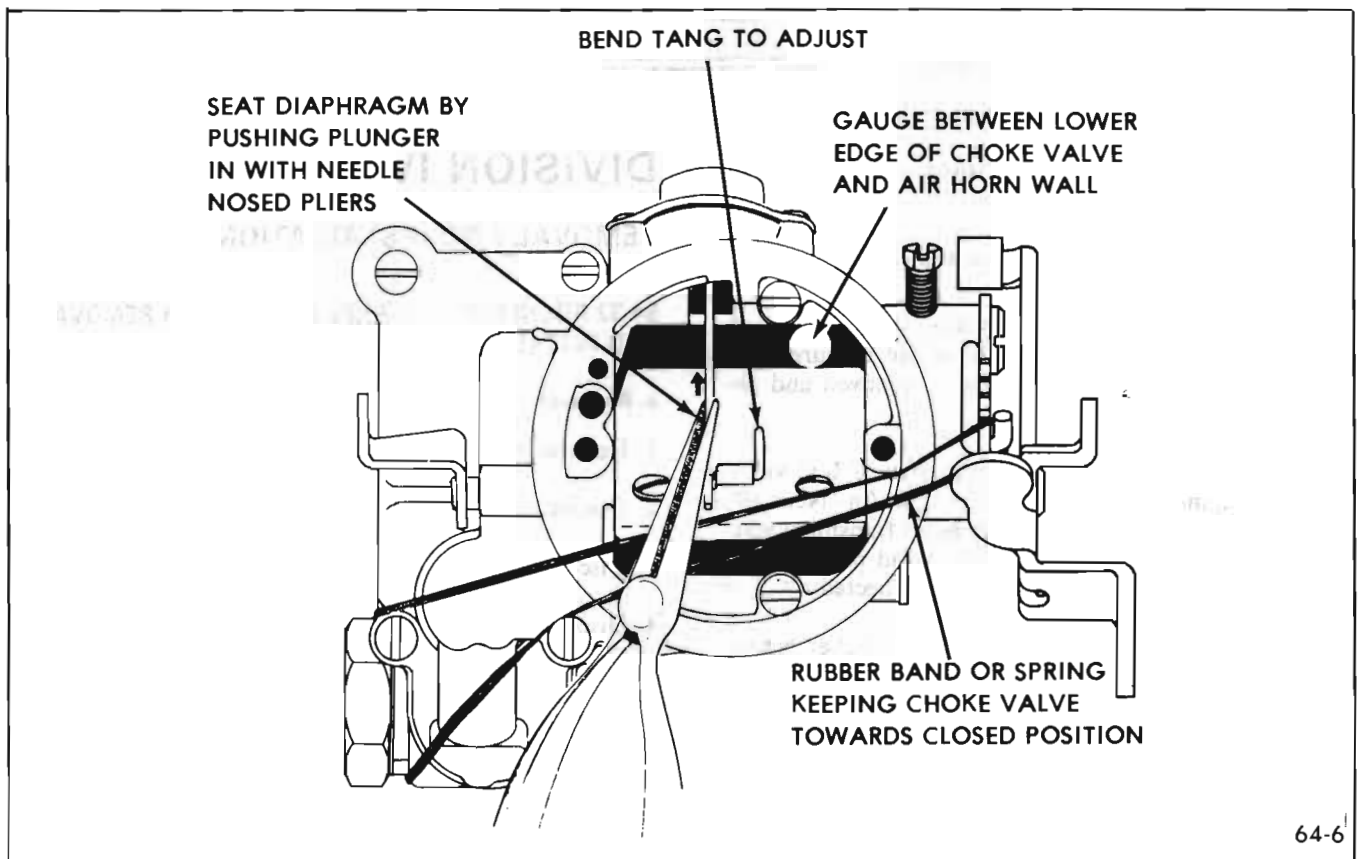
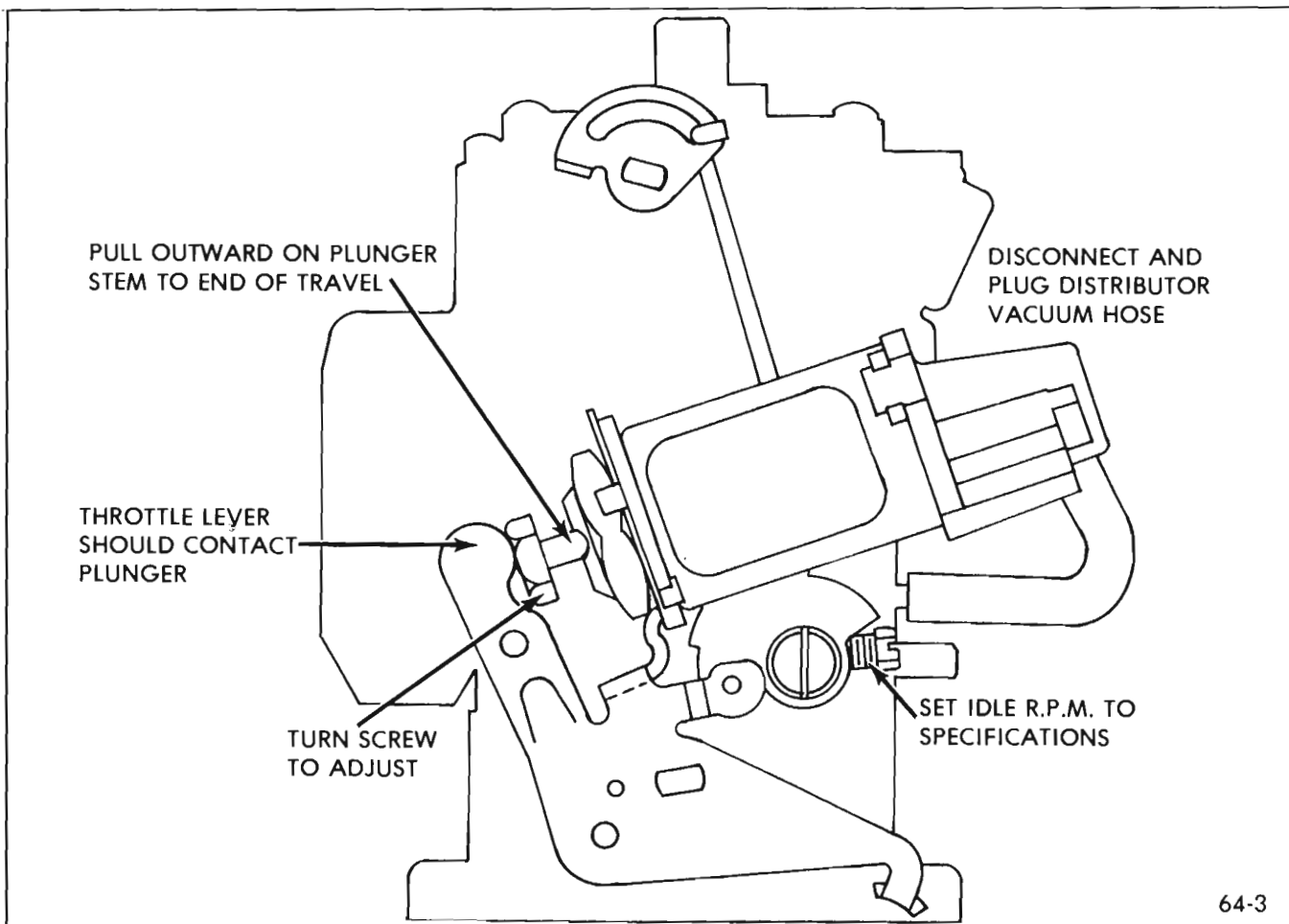

Figure 64-67 Vacuum Break Adjustment



64-3

Figure 64-68 Combined Emission Control Valve Adjustment

5. Bend end of vacuum break lever at point shown to adjust.

g. Combined Emission Control Valve Adjustment

This adjustment is to be made only after: 1) Replacement of the solenoid; 2) Major overhaul of the carburetor is performed; or 3) The throttle body is removed and replaced.

The following procedure is used to adjust the C.E.C. valve controlled engine speed on a running engine (in "Neutral" for manual or in "Drive" for automatic transmissions), with distributor vacuum hose removed and plugged and fuel tank hose from vapor canister disconnected.

1. Follow instructions on vehicle tune-up sticker before proceeding.
2. Manually extend the C.E.C. valve plunger to contact throttle lever.
3. Adjust plunger length to obtain specified engine speeds.
4. Reconnect distributor vacuum hose and fuel tank vapor hose.

DIVISION IV

REMOVAL AND INSTALLATION

64-32 ROCHESTER 1-BARREL CARBURETOR REMOVAL AND INSTALLATION

a. Removal

1. Remove air cleaner and gasket.
2. Disconnect fuel and vacuum lines from carburetor.
3. Disconnect C.E.C. valve electrical connections.
4. Disconnect choke rod.
5. Disconnect accelerator linkage.
6. Remove carburetor attaching nuts and/or bolts and remove carburetor.

b. Installation

1. Be certain throttle body and intake manifold sealing surfaces are clean.

2. Install new carburetor to manifold flange gasket, if required.
3. Install carburetor over manifold studs.
4. Install vacuum and fuel lines at carburetor.
5. Install attaching nuts and/or bolts.
6. Connect accelerator and choke linkage.
7. Install air cleaner.

64-33 COMBINED EMISSION CONTROL VALVE REMOVAL AND INSTALLATION

a. Removal

1. Remove vacuum hose from the C.E.C. valve and timed spark tube.
2. Bend back retaining tabs on lockwasher; then remove large C.E.C. valve nut and remove valve from bracket.

NOTE: *Do not remove C.E.C. valve bracket from the float bowl assembly, unless replacement of the bracket is necessary.*

Complete replacement instructions are included in the replacement bracket kit.

CAUTION: *Do not immerse the C.E.C. valve assembly in any type of carburetor cleaner.*

b. Installation

1. Install large C.E.C. valve nut and bend tabs over nut.
2. Replace vacuum hose on C.E.C. valve and timed spark tube.
3. Adjust valve, as in paragraph 64-31, sub-paragraph g.

DIVISION V

OVERHAUL AND MAJOR SERVICE

64-34 DISASSEMBLY, CLEANING AND INSPECTION OF ROCHESTER 1-BARREL CARBURETOR

a. Removal of Air Horn

1. Remove fast idle cam from boss on float bowl by removing attaching screw. Then remove fast idle cam from choke rod and choke rod from upper choke lever.

NOTE: *Upper choke lever is spun on end of choke shaft and cannot be removed.*

2. Remove thermostatic coil lever from opposite end of choke shaft by removing attaching screw.
3. Remove six air horn to float bowl attaching screws. There are (3) long and (3) short screws.

4. Remove air horn by lifting straight up. Invert air horn and place on clean bench. Air horn to bowl gasket can remain on bowl for removal later.

b. Disassembly of Air Horn

1. Remove two vacuum break diaphragm cover screws. Then carefully remove diaphragm cover.

2. To remove vacuum break diaphragm and plunger rod, hold choke valve wide open. Then push upward on eyelet on choke valve at a 45 degree angle until the looped end of rod slides off wire lever attached to the choke valve. Then remove diaphragm and plunger rod assembly through the hole in air horn.

3. If desired, the choke valve, vacuum break lever, and choke shaft can be removed from air horn by first removing the thermostatic coil lever from the end of choke shaft, by removing the attaching screw. After removing the thermostatic coil lever, remove the choke valve and choke shaft from air horn.

NOTE: *The choke valve screws are held in place by lock-tite so it will be necessary to restake after assembly.*

4. No further disassembly of the air horn is necessary. The pressure relief valve disc need not be removed from top of air horn for cleaning purposes. If the valve is defective, air horn replacement is necessary.

c. Disassembly of Float Bowl

1. Remove air horn to float bowl gasket. Gasket is slit next to metering rod lever so that it can be slid over lever for ease in removal.

2. Remove float assembly from float bowl by lifting upward on float hinge pin. Remove hinge pin from float arm.

3. Remove float needle, then remove float needle seat and gasket. To prevent damage to needle seat, use a screwdriver which completely fills slot.

4. Remove fuel inlet nut and gasket, then remove filter element and pressure relief spring.

5. Using long nosed pliers, remove "T" pump discharge guide. Pump discharge spring and ball may be removed by inverting bowl.

6. The idle tube can be removed at same time by inverting bowl.

7. To remove accelerating pump plunger and power piston - metering rod assemblies, remove actuating lever on throttle shaft by removing attaching screw in end of shaft.

8. Hold the power piston assembly down in float bowl, then remove power piston drive link by sliding out of hole in power piston plunger rod. The power piston - metering rod assembly can now be removed from float bowl.

9. The metering rod can be removed from holder, if necessary, by pushing downward on end of rod against spring tension. Then slide narrow neck of rod out of slot in rod holder.

10. Remove power piston spring from power piston cavity.

11. Hold the pump plunger down in bowl cavity and remove drive link from pump plunger shaft by rotating link until squirt on link aligns with notch in plunger shaft.

12. Remove pump plunger assembly from float bowl.

13. Remove pump return spring from pump well.

14. Remove main metering jet from bottom of fuel bowl.

15. Slow idle screw and fast idle cam can be removed at this time if desired.

No further disassembly of the float bowl is required.

d. Removal and Disassembly of Throttle Body

1. Invert carburetor bowl on bench and remove two throttle body to bowl attaching screws. Throttle body and insulator gasket may now be removed from float bowl.

2. No further disassembly of the throttle body is necessary, unless the idle mixture needle is damaged or the idle channels need cleaning. If necessary to remove the idle mixture needle, destroy plastic limiter cap, as a new one is provided in the overhaul kit.

NOTE: *Due to the close tolerance fit of throttle valve in the bore or the throttle body, do not remove the valve or shaft.*

e. Cleaning and Inspection

The carburetor should be cleaned in a cold immersion type cleaner.

1. Thoroughly clean carburetor castings and metal parts in an approved carburetor cleaner.

CAUTION: *Any rubber parts, plastic parts, diaphragms, pump plungers, should not be immersed in carburetor cleaner. However, the air horn which has the plastic vent valve guide and cranking enrichment valve will withstand normal cleaning in carburetor cleaner.*

2. Blow out all passages in castings with compressed air. Do not pass drills through jets or passages.

3. Inspect idle mixture needle for damage.

4. Examine float needle and seat assembly for wear. Install a new factory matched set if worn.

5. Inspect upper and lower casting sealing surfaces for damage.

6. Inspect holes in levers for excessive wear or out of round condition. If levers or rods are worn they should be replaced.

7. Examine fast idle cam for excessive wear or damage.

8. Check throttle and choke levers and valves for binds and other damage.

9. Replace filter element.

10. Check all springs for distortion or loss in tension, replace as necessary.

64-35 ASSEMBLY AND INTERNAL ADJUSTMENT OF ROCHESTER 1-BARREL CARBURETOR

a. Assembly and Installation of Throttle Body

1. If removed, install idle mixture needle and spring until lightly seated. Back out four turns as a preliminary idle adjustment.

NOTE: *The plastic limiter cap should not be installed on the idle mixture needle until the idle mixture has been adjusted as specified on the engine.*

2. Invert float bowl and install new throttle body to bowl insulator gasket.

3. Install throttle body on bowl gasket so that all holes in throttle body are aligned with holes in gasket.

4. Install two throttle body to bowl attaching screws. Tighten evenly and securely (12 to 15 foot lbs. of torque). The throttle body to bowl screws do not use lockwashers, as they have an interference fit designed into the thread for holding proper torque.

b. Assembly of Float Bowl

1. Install idle stop screw, if removed.

2. Install round seal into recess in idle compensator cavity and float bowl, then install idle compensator assembly.

3. Install idle compensator cover, retaining with two attaching screws. Tighten securely.

4. Install main metering jet into bottom of fuel bowl. Tighten securely.

5. Using tool, install float needle seat and gasket.

6. Install idle tube flush with bowl casting.

7. Install pump discharge ball, spring and "tee" retainer into pump discharge hole.

8. Push down on pump discharge "tee" until flush with bowl casting.

9. Install fuel filter spring, filter, inlet nut, and gasket.

10. Install accelerator pump return spring into bottom of pump well. Press downward on spring until seated in cavity.

11. Install power piston return spring into piston cavity in the bowl.

12. Install power piston actuating rod (right angle end) into slot in the power piston.

13. Install power piston, metering rod, and actuating rod assembly into the float bowl. End of actuating rod must enter hole in bowl. Locate metering rod into jet orifice.

14. Install pump plunger assembly into pump well with actuating lever protruding through bottom of bowl casting. Push downward on pump lever and install pump assembly drive link into slot at lower end of pump shaft. Ends of drive link point inward toward carburetor bore. Tangs on ends of drive link retain link to pump shaft end pump actuating lever.

15. Install lower end of pump link into actuator lever which fits on the end of the throttle shaft.

16. Install curved power piston actuating link into throttle actuating lever. Lower end of link protrudes outward away from throttle bore and has a tang which retains the link to the actuator lever.

17. Before fastening power piston and pump actuator lever to end of throttle shaft, hold power piston assembly down and slide upper end of curved power piston actuator link into end of power piston actuator rod.

18. Install actuator lever on end of throttle shaft by aligning flats on lever with flats on shaft. Install lever retaining screw and tighten securely.

19. Install float needle valve into needle seat.

20. Install float hinge pin into float arm, then install float and hinge pin into float bowl.

Float Level Adjustment

1. Hold float retainer firmly in place and float arm against top of float needle, by pushing downward on float arm at point between needle seat and hinge pin. See Figure 64-69.

2. With adjustable T-scale measure distance from top of float at toe to float bowl gasket surface (gasket removed). Measurement should be $9/32"$ at point $1/16"$ in from end of flat surface at float toe (not on radius).

Metering Rod Adjustment

1. Remove metering rod by holding throttle valve wide open. Push downward on metering rod against spring tension, then slide metering rod out of slot in holder and remove from main metering jet.

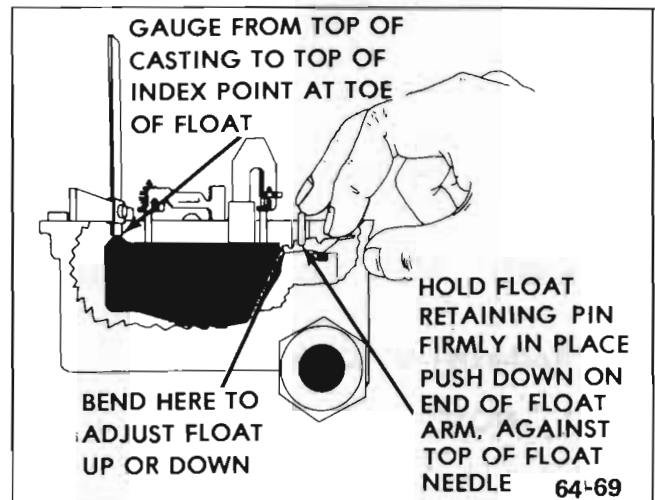

Figure 64-69 - Float Level Adjustment

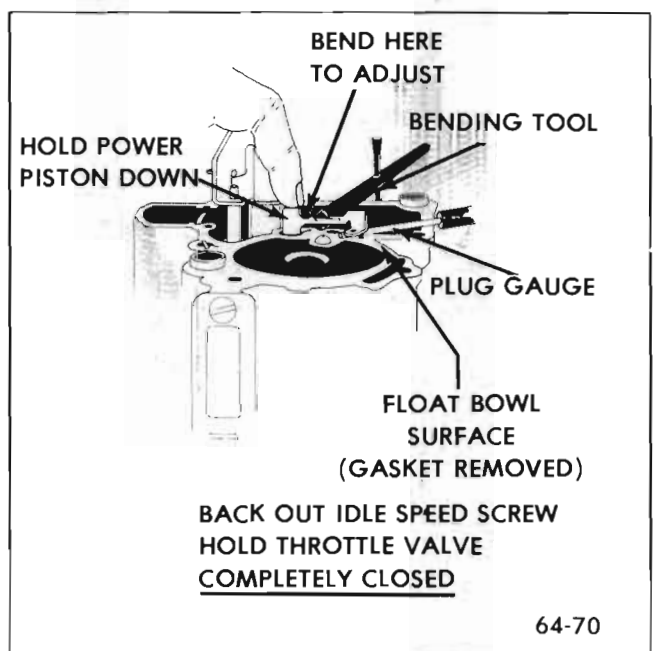

Figure 64-70 - Metering Rod Adjustment

2. With throttle valve completely closed, hold power piston down against its stop.

3. Holding downward pressure on power piston, swing metering rod holder over flat surface of bowl casting next to carburetor bore.

4. Use specified plug gage and insert between bowl casting sealing bead and lower surface of metering rod holder. Gage should have a slide fit between both surfaces, as shown in Figure 64-70.

5. To adjust, carefully bend metering rod holder up or down at point shown.
6. After adjustment install metering rod, tension spring and retaining clip.
7. Install air horn gasket on float bowl by carefully sliding slit portion of gasket over metering rod holder. Then align gasket with dowels provided on top of bowl casting and press gasket firmly in place.

c. Assembly of Air Horn

1. Install choke shaft, choke valve and vacuum break lever, if removed. Align choke valve, tighten two retaining screws and stake securely.

2. Install vacuum break diaphragm and plunger into cavity at side of air horn. With choke valve in the open position, hold eyelet tang at 45 degree angle. Slide eyelet of plunger rod over end of vacuum break lever on the choke valve shaft.

3. Seat vacuum break diaphragm over sealing bead on air horn casting. With diaphragm held in place, carefully install diaphragm cover and two retaining screws. Tighten screws securely.

4. Install air horn to float bowl by lowering gently onto float bowl until seated. Install three long and three short air horn to float bowl attaching screws. Tighten securely using tightening sequence.

Division VI Specifications

64-34 Rochester MV Carburetor Calibrations

NOTE: All carburetors have a color code paint mark and a part number stamped on the float bowl for identification.

Model Designation	
Number of Barrels	
Code Letters	
Part Number	
Throttle Bore	
Main Metering Jet	

250 Eng. Man. Trans.	250 Eng. Auto. Trans.
MV	MV
1	1
7041017	7041014
1 11/16"	1 11/16"
.106	.106

NOTE: No Changes Are Required for Altitude.

Idle Tube Restriction	
Idle Needle Hole	
Spark Holes	
Pump Discharge Holes	

.043	.042
.059	.062
.200 x .045	.200 x .045
.045	.030

64-35 Rochester MV Carburetor Adjustments

Float Level Adjustment	
Choke Rod Adjustment	
Choke Unloader Adjustment	
Idle Speed (On Car)	
Idle Vent Adjustment	
Vacuum Break Adjustment	
Choke Coil Rod Adjustment	
Metering Rod Adjustment	
C.E.V. Valve Adjustment	

1/4"	1/4"
.180	.160
.350"	.500"
550 RPM	500 RPM
.050	.050
.225	.225
1 Rod Dia Past Top of Hole	
.080"	.080"
850 RPM	650 RPM

5. Assemble choke rod into the slot in the upper choke lever. End of rod points away from air horn casting when installed properly.

6. Install fast idle cam to lower end of choke rod by rotating until slot in fast idle cam slides over tang on rod. Steps on the fast idle cam should face tang on throttle lever. Install fast idle cam screw. Tighten securely.

7. Install C.E.C. valve into bracket on float bowl. Install lockwasher and large retaining nut and tighten securely.

Then, bend retaining ears over on flats of nut so that the nut is locked securely in place.

8. Install vacuum hose to top tube on float bowl and to outer tube on the C.E.C. valve.

NOTE: Refer to the adjustment chart for the remaining adjustments; adjustments must be performed in the sequence shown. Slow idle RPM specifications are also shown on the chart.

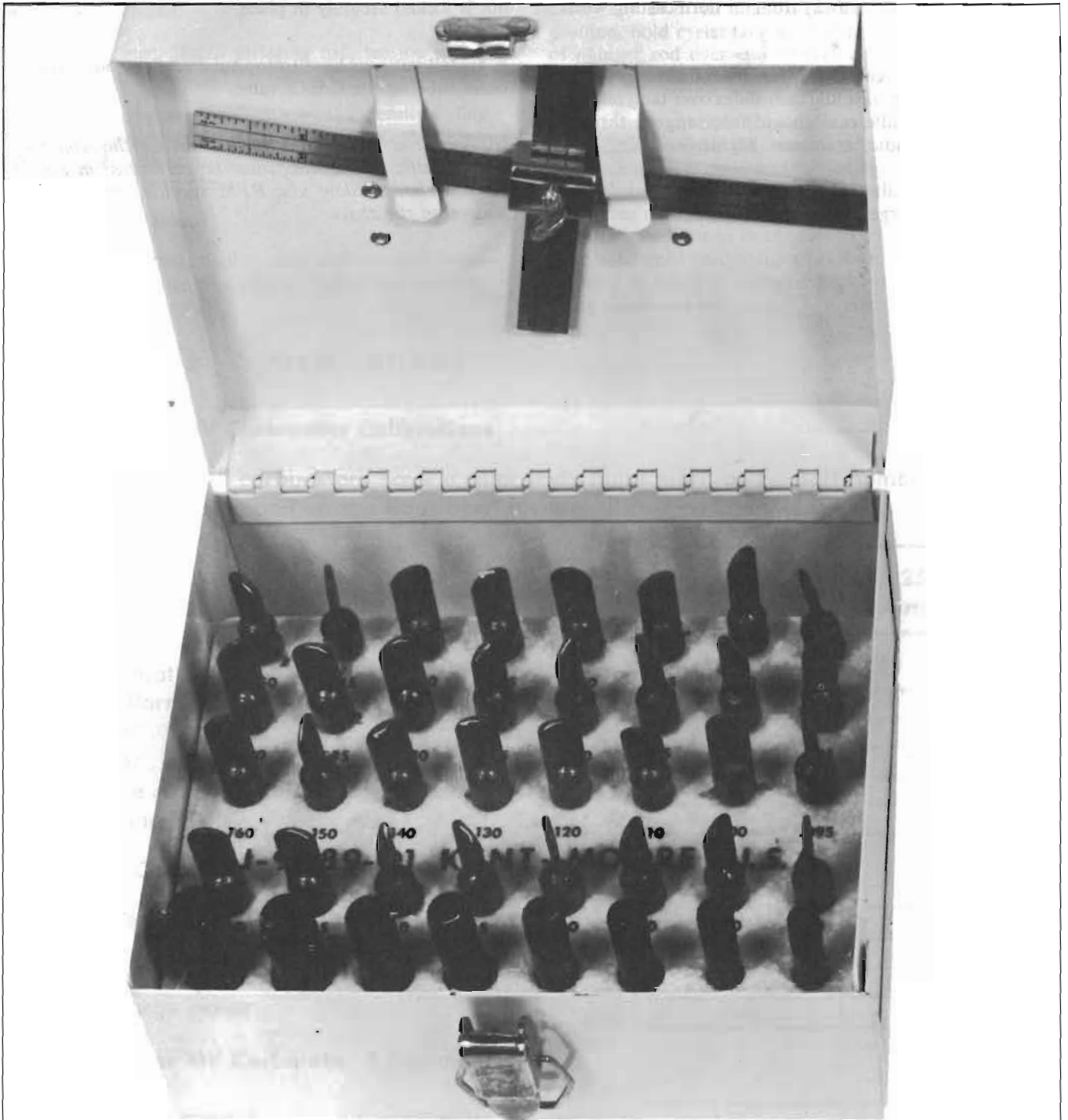

J-9789-01

UNIVERSAL CARBURETOR GAUGE SET

64-71

Figure 64-71 - Engine Fuel System Special Tools