

SECTION A

CRUISE MASTER ALL SERIES

CONTENTS

Division	Subject	Paragraph
I	TROUBLE DIAGNOSIS: Cruise Master Trouble Diagnosis	65-1
II	DESCRIPTION AND OPERATION: Description and Operation of Cruise Master	65-2
III	ADJUSTMENTS AND MINOR SERVICE: Cruise Master Adjustments and Service Procedures	65-3
IV	REMOVAL AND INSTALLATION: (Not Applicable)	-
V	OVERHAUL AND MAJOR SERVICE: (Not Applicable)	-
VI	SPECIFICATIONS: (Not Applicable)	-

DIVISION I

TROUBLE DIAGNOSIS

65-1 CRUISE MASTER TROUBLE DIAGNOSIS

a. Cruise Master Quick Check

Refer to Trouble Diagnosis Chart in rear of section.

b. Electrical Check Out

1. Check all fuses and connections.
2. Check adjustment of cruise brake release switch and brake release valve. See paragraph 65-3,b.
3. Check cruise control engagement switch as follows:
 - (a) Disconnect switch connector from wiring harness at lower part of steering column (refer to Figure 65- 10 for location of terminal numbers and for circuit function) as required perform the following test.

Test No. 1 - Connect ohmmeter between Terminal No. 1 (brown wire) and Terminal No. 2 (blue wire). Continuity shall be maintained until switch is depressed all the way in.

Test No. 2 - Connect ohmmeter between Terminal No. 1 (brown wire) and Terminal No. 3 (black). No continuity shall be shown; however, when the button is depressed to the detent, continuity shall be indicated. When the button is pressed all the way down, no continuity shall be shown.

Test No. 3 - Connect ohmmeter between Terminal No. 2 (blue wire) and Terminal No. 3 (black). Button released, no continuity; however, when the button is depressed partially and fully, continuity shall be shown.

4. With the cruise control engagement switch connector disconnected as in Step 3, above, disconnect battery and check wiring harness and circuitry as follows:

(a) Connect an ohmmeter at appropriate terminals and junction points as indicated in the schematic diagram of Figure 65-10 to measure the following resistances:

- (1) Harness brown-white resistance wire, R1, which is approximately 40 ohms.
- (2) Transducer solenoid coil resistance, which is 5.2 plus or minus 0.2 ohms.

Note that these resistance values are given for parts at normal room temperatures of 68-72 degrees F. Use care to disconnect transducer as needed to eliminate possible parallel paths to ground when making resistance checks. Except for the brown-white resistance wire, all harness wires shall indicate zero resistance (continuity) when

checked per the schematic of Figure 65-10. If values of resistance other than those indicated above occur, take corrective action and repair or replace as required.

(b) Check cruise lamp bulb if indicated. Replace if required.

(c) Replace cruise control switch connector and reconnect battery.

DIVISION II

DESCRIPTION AND OPERATION

65-2 DESCRIPTION AND OPERATION OF CRUISE

MASTER

a. Introduction

Cruise Master is a driver-operated cruise control system which maintains desired vehicle speed by regulating throttle position. It may be either factory or dealer installed.

b. Driver Operation

1. *Engagement* - The driver accelerates to the speed at which he desires to cruise and depresses and releases the cruise control engagement switch button located at the end of the directional signal lever. The cruise system immediately takes over speed control and, within engine limitation, maintains this speed regardless of changes in terrain.

The engagement switch button performs these functions:

- (a) When depressed to the detent, it engages the system.
- (b) When depressed fully and held there, it disengages the system.
- (c) When released completely, it holds the system in engagement. (The lowest speed at which the system should be used is 40 MPH).

When the system is engaged the cruise lamp will light, indicating that the system is engaged.

2. *Disengagement* - The system automatically disengages whenever the brake is depressed or the ignition switch turned off.

The cruise lamp will go out, indicating that the system is no longer in use.

3. *Speed Adjustment* -

- (a) Upward - Depress the accelerator pedal to the new desired speed. Then fully depress and slowly release the

cruise control engagement switch button. The system re-engages at the higher speed when the button is released through the detent.

(b) **Downward** - Disengage the system by depressing the engagement switch button fully and holding it there until the car has decelerated to the new desired speed; then release the button slowly.

4. **Override** - The accelerator pedal may be depressed at any time to override the cruise system. Release of the accelerator pedal will return the car to the previous cruise speed.

c. Cruise Master Units

(Figures 65-8 and 9 show the units in the installed position on the three series of vehicles.)

1. **The engagement switch**, which is located at the end of the directional signal lever, is used to control the system and for upward and downward speed adjustments.

2. **The speed transducer**, which is mounted in the speedometer cable line, is a combination speed sensing device and control unit. When engaged, it senses vehicle speed and positions the power unit to maintain the selected speed. It also provides a ground path for the cruise lamp.

3. **The power unit**, which is mounted at the rear of the engine, is connected by a ball chain to the throttle linkage. It opens or closes the throttle as dictated by the speed transducer.

4. **The cruise brake release switch**, which is mounted on the brake pedal bracket, disengages the system electrically when the brake pedal is depressed.

5. **The cruise brake release valve**, which is mounted on the brake pedal bracket, disengages the system pneumatically when the brake pedal is depressed.

6. **The cable and casing assemblies** drive the transducer and speedometer.

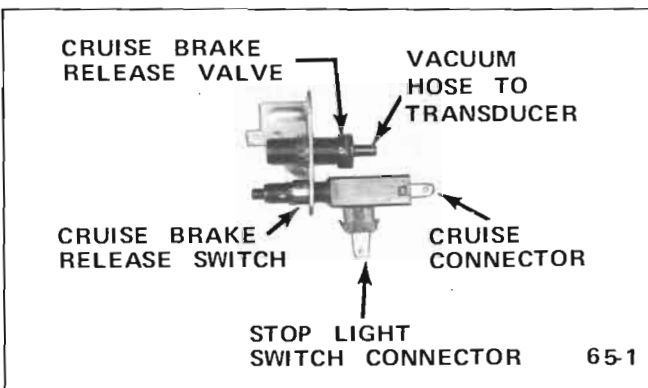

Figure 65-1 Cruise Brake Release Switch and Valve

d. Operation of Cruise Master

The transducer consists of two sub-assemblies: The magnet housing assembly and the solenoid and clutch housing assembly. The magnet housing assembly contains the drive adapter assembly, magnet and shaft assembly, and the speed disc field plate and spindle assembly. See Figures 65-2 and 65-3.

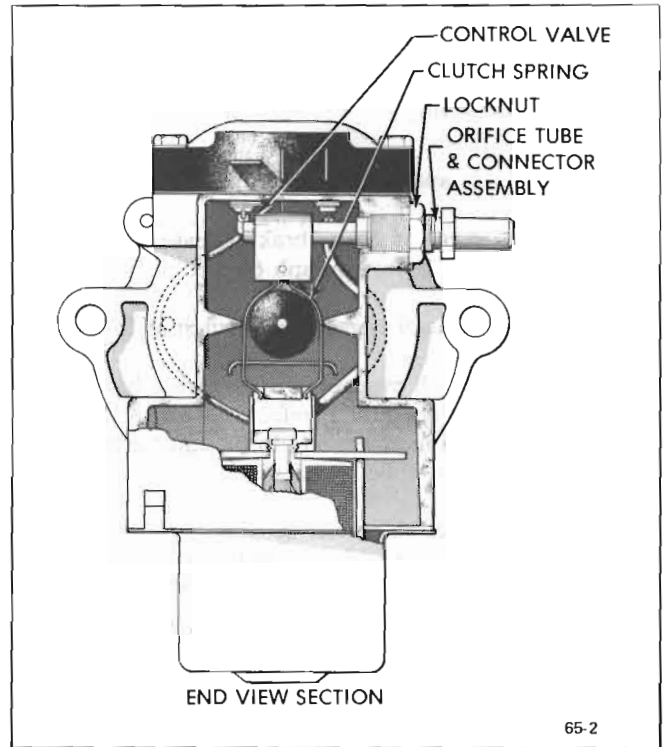

Figure 65-2 - Cruise Master Speed Transducer-End Section View

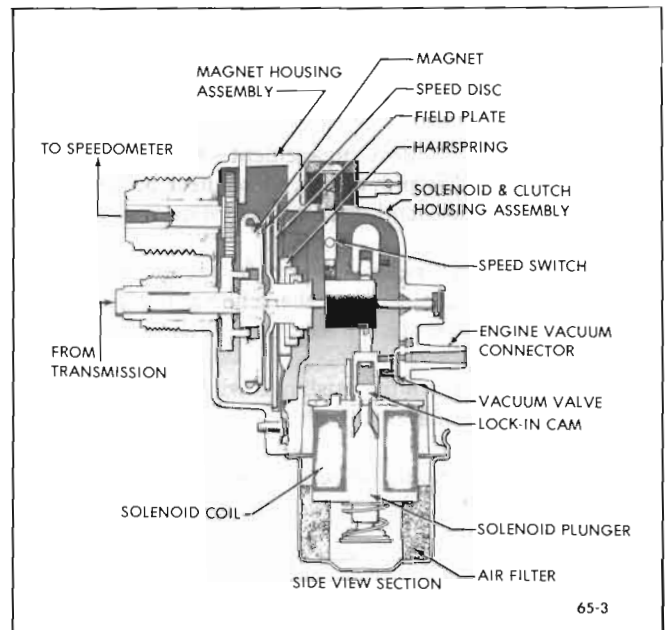

Figure 65-3 Cruise Master Speed Transducer - Side View Section

The solenoid and clutch housing contains the orifice tube and connector assembly, the control valve, the engagement clutch spring, the low speed switch, the engagement solenoid assembly, and the air filter assembly.

The power unit consists of a diaphragm and return spring. The vacuum level of the sealed chamber is controlled by the transducer. The ball chain connects directly to the throttle linkage to control carburetor throttle position. See Figure 65-4.

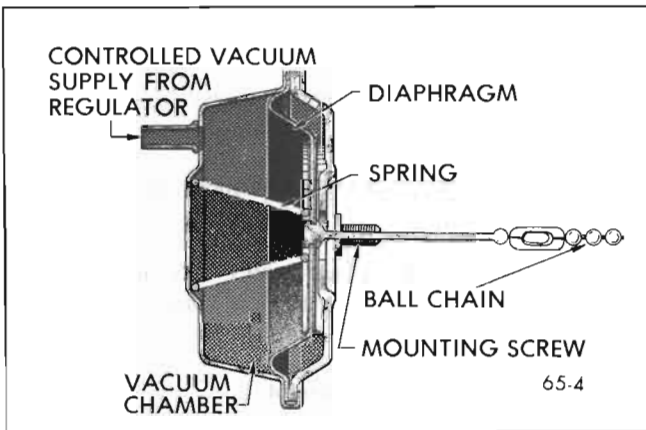

Figure 65-4 - Power Unit

The engage switch mounted in the turn signal lever is a single pole, three-position type. See Figure 65-10. This switch normally has car voltage applied to switch terminal No. 1, except when the ignition is off, or the cruise release switch is open, and in the rest position Terminals No. 1 and No. 2 are closed. This supplies car voltage through a 40 ohm resistor to the hold terminal on the transducer. This resistor limits the current flow to the transducer so that there is insufficient energy to engage the solenoid; yet, there is enough to hold the solenoid in the engaged position once it has been engaged. With the engage switch in the detent or middle position, Terminals No. 1, No. 2, and No. 3 are closed. This supplies car voltage to the transducer, through the engage terminal on the transducer, which will engage the transducer solenoid mechanism if the low speed switch is closed. The low speed switch is open below approximately 35 mph and closed above 35 mph. Once the cruise system is engaged, the turn signal engage switch can be released because there is sufficient current flow through the 40 ohm resistor to keep the system engaged. The third switch position is when it is completely depressed (past the detent position). At this time, voltage is removed from Terminals No. 2 and No. 3. This disengages the cruise system and is normally used as a trim-down operation to reduce cruise speed. When the switch is slowly released from this trim-down position, the switch goes through the engage position before returning to the normal rest position, there re-engages the system at that time.

Theoretically, the rubber clutch behaves as does a speedometer pointer - that is, it moves either clockwise or counterclockwise in proportion to the speed of the rotating magnet. Since the control valve is mechanically connected to the clutch spring, the valve moves either to the right or to the left, proportional to the speed of the rotating magnet. This motion of the control valve changes the size of the openings in the orifice tube. Also, energizing the transducer positions the vacuum valve within the transducer to connect engine vacuum directly to the power unit. See Figure 65-10.

The transducer is a device which has two primary functions. First, it is a vacuum switch which, when engaged by the driver, supplies vacuum to a "Tee" fitting. Second, it meters a small variable quantity of air to the "Tee" fitting where it blends with vacuum, thus providing the power unit with controlled vacuum which will maintain the selected speed. If the transducer begins to supply less bleed air (vehicle speed decreasing) the vacuum in the chamber increases and the diaphragm moves toward the vacuum port. If the transducer begins to supply more bleed air (vehicle speed increasing) the vacuum in the chamber drops and the diaphragm moves away from the vacuum port. In operation, at cruise speed, a proper balance of air and vacuum is blended at the "Tee" fitting and is imposed upon the power unit to maintain an "On Speed" cruise condition. See Figure 65-2 and 65-3.

If the car goes upgrade, there is a tendency for speed reduction. When speed reduction occurs (refer to Figure 65-5) the valve, wire and spring assembly moves in the direction which makes the window openings smaller, reducing the amount of atmospheric air to the power unit thereby increasing the vacuum level in the power unit. This draws in the diaphragm, thus increasing the carburetor throttle opening via the connecting ball chain and maintaining cruise speed.

Conversely, if the car goes down grade, there is a tendency to exceed the set speed. In this case, the valve moves in the direction which increases the size of the window openings. This admits a larger volume of air to the power unit, reducing its vacuum level and in turn allowing the diaphragm to move out and reduce the carburetor throttle

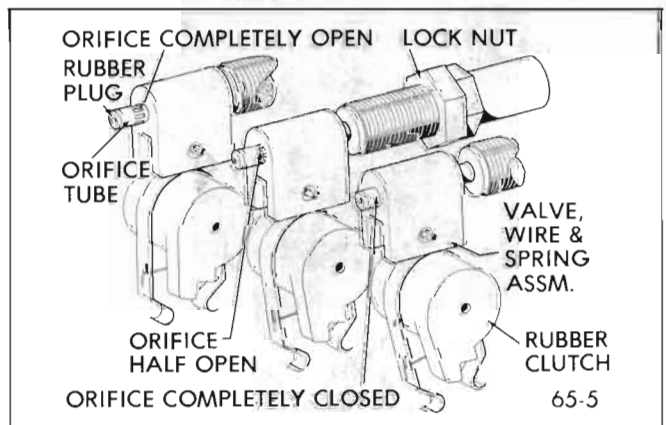

Figure 65-5 - Transducer Air Bleed Orifice Openings

65-6 CRUISE MASTER—ALL SERIES

opening, thereby maintaining cruise speed under normal terrain conditions.

Both overspeed and underspeed tendencies are immediately corrected since 3 MPH speed change will result in a change in the size of window openings capable of moving the power unit through its complete range. This means that the throttle will be moved through its complete cruise range with a speed change of 3 MPH. This results in accurate control of cruise speed.

DIVISION III

ADJUSTMENTS AND MINOR SERVICE

65-3 CRUISE MASTER ADJUSTMENTS AND SERVICE PROCEDURES

a. Power Unit Bead Chain Adjustment

1. Adjust engine hot idle speed and mixture, then shut off engine.
2. Check bead chain slack by unsnapping swivel from ball stud and holding chain taut at ball stud; center of swivel should extend 1/8 inch beyond center of ball stud. See Figure 65-8 or 9.
3. Adjust bead chain slack, if necessary, by sliding sleeve back on chain and removing loose rivet. Move swivel on ball chain until slack is correct, reinstall rivet and again slide sleeve over rivet.

b. Brake Release Switch and Valve Adjustment

ORIFICE TUBE &
CONNECTOR
ASSEMBLY

LOCK NUT

OUTPUT TO
SPEEDOMETER

INPUT FROM
TRANSMISSION

AIR FILTER & SOLENOID
HOUSING COVER

65-6

Figure 65-6 - Speed Transducer

With brake pedal fully depressed, push switch and valve forward until they stop against bracket or arm, pull pedal rearward with 15-20 lbs. force to properly adjust switch and valve.

c. Cruise Speed Adjustment

If the car cruises at a speed above or below the engagement speed, this error can be corrected with a simple adjustment of the orifice tube in the transducer. See Figure 65-6.

1. To check cruise speed error, engage Cruise Master at exactly 60 MPH.
2. If car cruises below engagement speed, screw orifice tube outward.
3. If car cruises above engagement speed, screw orifice tube inward.

NOTE: *Each 1/4 turn of the orifice tube will change cruise speed approximately one MPH. Snug-up lock nut after each adjustment before testing.*

d. Transducer Air Filter Replacement

1. Replace air filter when it becomes contaminated. When making the replacement:

(a) Place polyurethane filter in bottom of solenoid and filter cover. Note rectangular shape of filter and cover. See Figure 65-7.

(b) Position the solenoid and filter cover and its rubber gasket to the solenoid housing casting and *secure with the cover retaining clips*. Use care to insure that a tight gasket seal is obtained.

e. Removal of Cruise Master Actuating Engagement Switch

NOTE: *Shift Lever must be in low*

POLYURETHANE FILTER

SOLENOID & FILTER COVER

SOLENOID &
FILTER COVER
GASKET

65-7

Figure 65-7 - Replacing Cruise Master Air Filter

1. Remove horn actuator and steering wheel.
2. Remove cover plate (three screws).
3. Remove turn signal lever screw and conduit from wire assembly.
4. Attach fine pliable wire through hole in connector. Tape end of wire and connector.
5. Pull switch and wire assembly through column. (Threading pliable wire).
6. Attach and tape wire to new connector.
7. Pull connector and wire through column.
8. Replace conduit on wire assembly.
9. Install turn signal lever screw.
10. Install cover plate.
11. Install steering wheel and horn actuator.

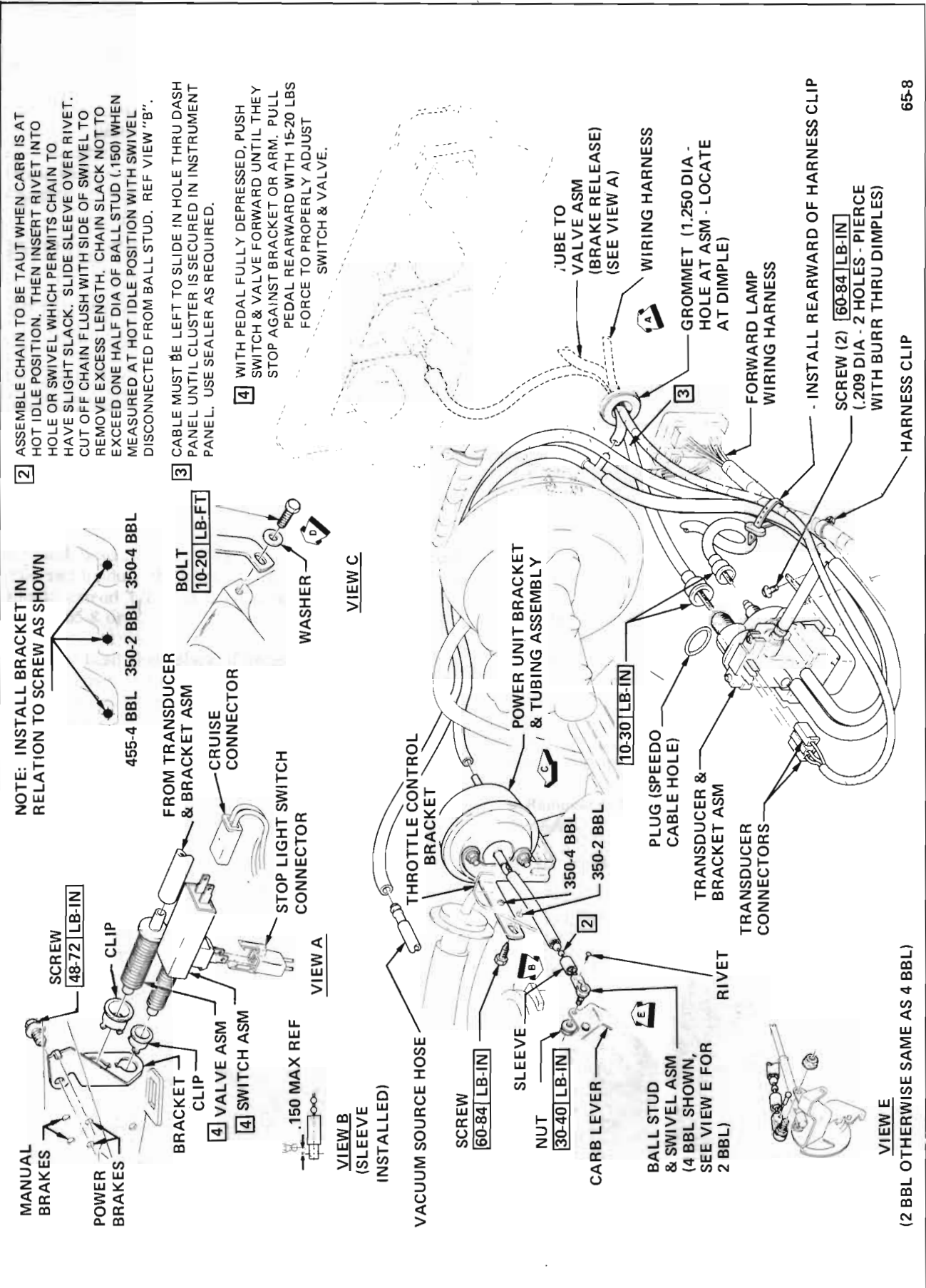
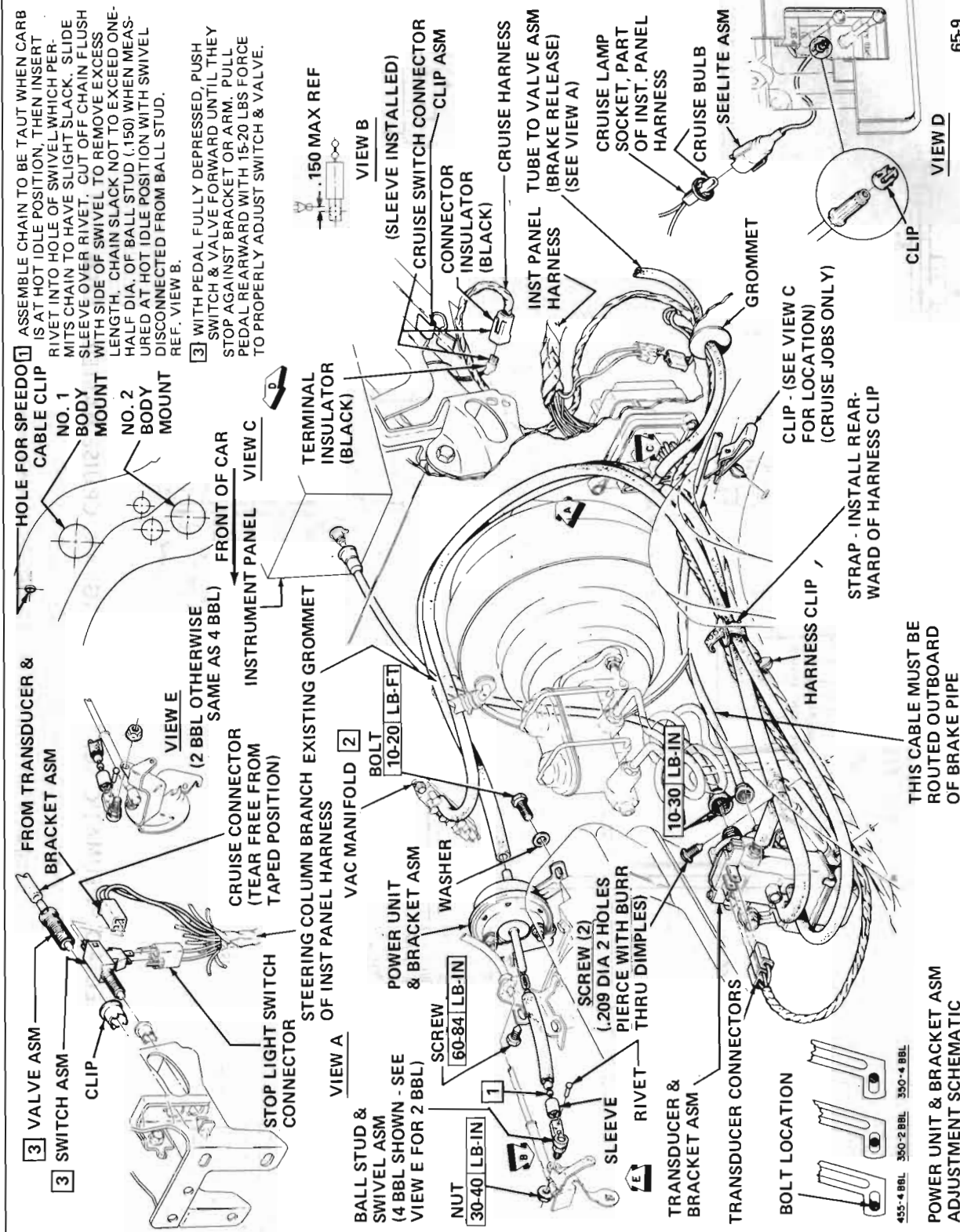

Figure 65-8 -Cruise Master Installation 43-44000 Series



65-9

Figure 65-9 - Cruise Master Installation 45-46-48-49000 Series

Buick Cruise Master Quick Checks
 Check 1 - For inoperative systems.
 Check 2 - For systems with erratic cruise performance.
 Make all tests with transmission selector in "Park" and parking brake on except where indicated otherwise.
 Reconnect any disconnected hoses and/or electrical connectors in proper manner at completion of test.
 For detailed information, refer to the Service Manual.

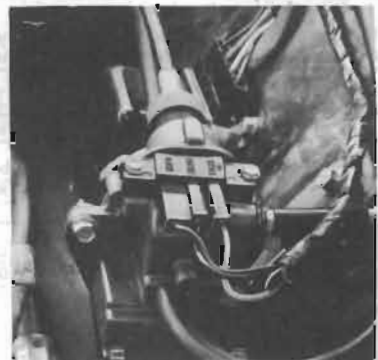
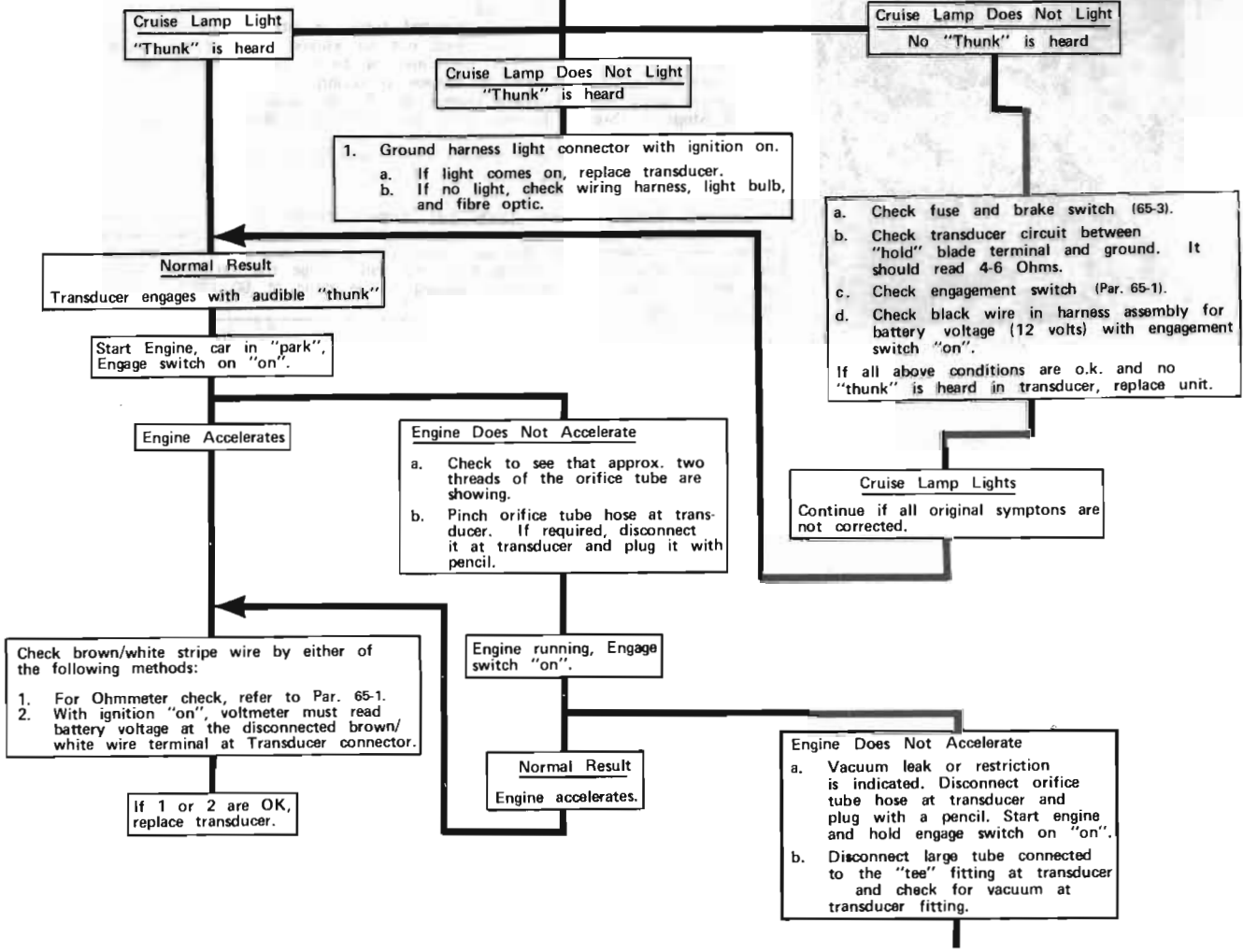

FIGURE 1

CHECK 1

Preliminary inspection - Make physical inspection of all components. Check for electrical (see Figure 1) or mechanical disconnections, pinched, misrouted or disconnected vacuum hoses. If no defects are found, proceed as follows:
 1. Unplug two terminal connector at Transducer.
 2. Reconnect connector as per Figure 2.
 3. Turn "on" ignition key, (do not start engine) and depress engage switch to detent and hold at detent.



- Figure 65-11 - Cruise Master Trouble Chart

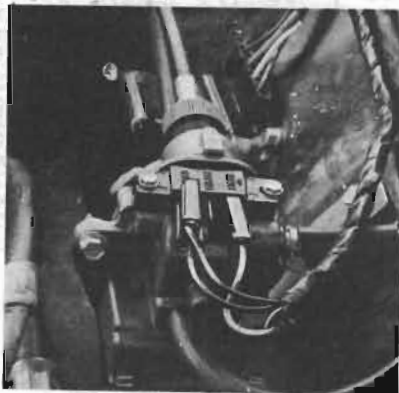
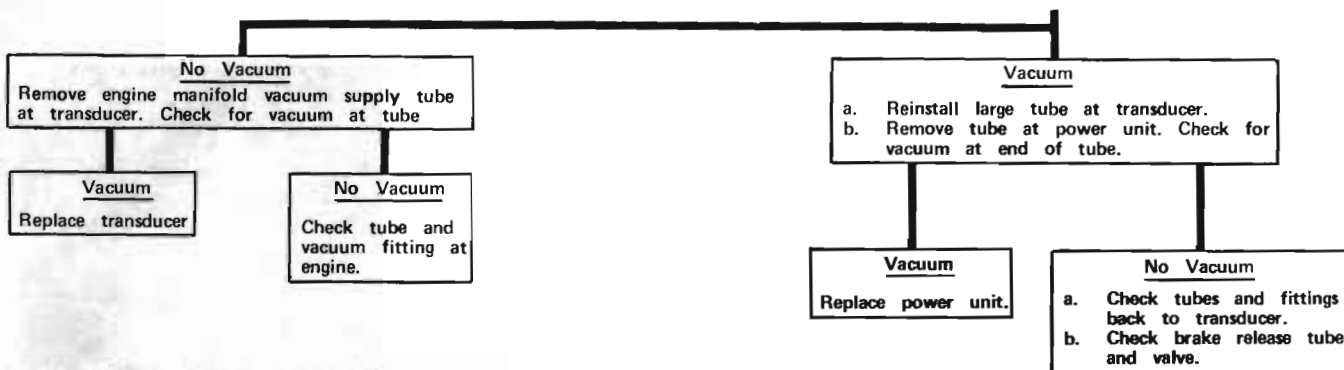

FIGURE 2

CHECK 2

1. Check bead chain -- at hot idle bead chain must be snug, but no so tight as to effect idle speed.
2. Check for pinched, plugged, damaged tubes or fittings and their routing.
3. Check cable routing -- they must not be kinked or have too sharp a turning radius. Check drive cables for kinks or bent tips. Ferrules must be snug.
4. Check for a binding throttle linkage condition.
5. Check adjustment of brake release switch (Par. 65-3).
6. If Steps 1 thru 5 do not solve the problem, replace Transducer.

Special note pertaining to engagement-cruising speed zeroing.

(Preliminary check - approximately two threads should be shown on orifice tube adjacent to lock nut.) If the car cruises below engagement speed, screw the orifice tube outward. If the car cruises above the engagement speed, screw the orifice tube inward. Each 1/4 turn will change the car speed approximately one MPH. Engagement accuracy testing to be done at 60 MPH. Snug up lock nut after each adjustment.

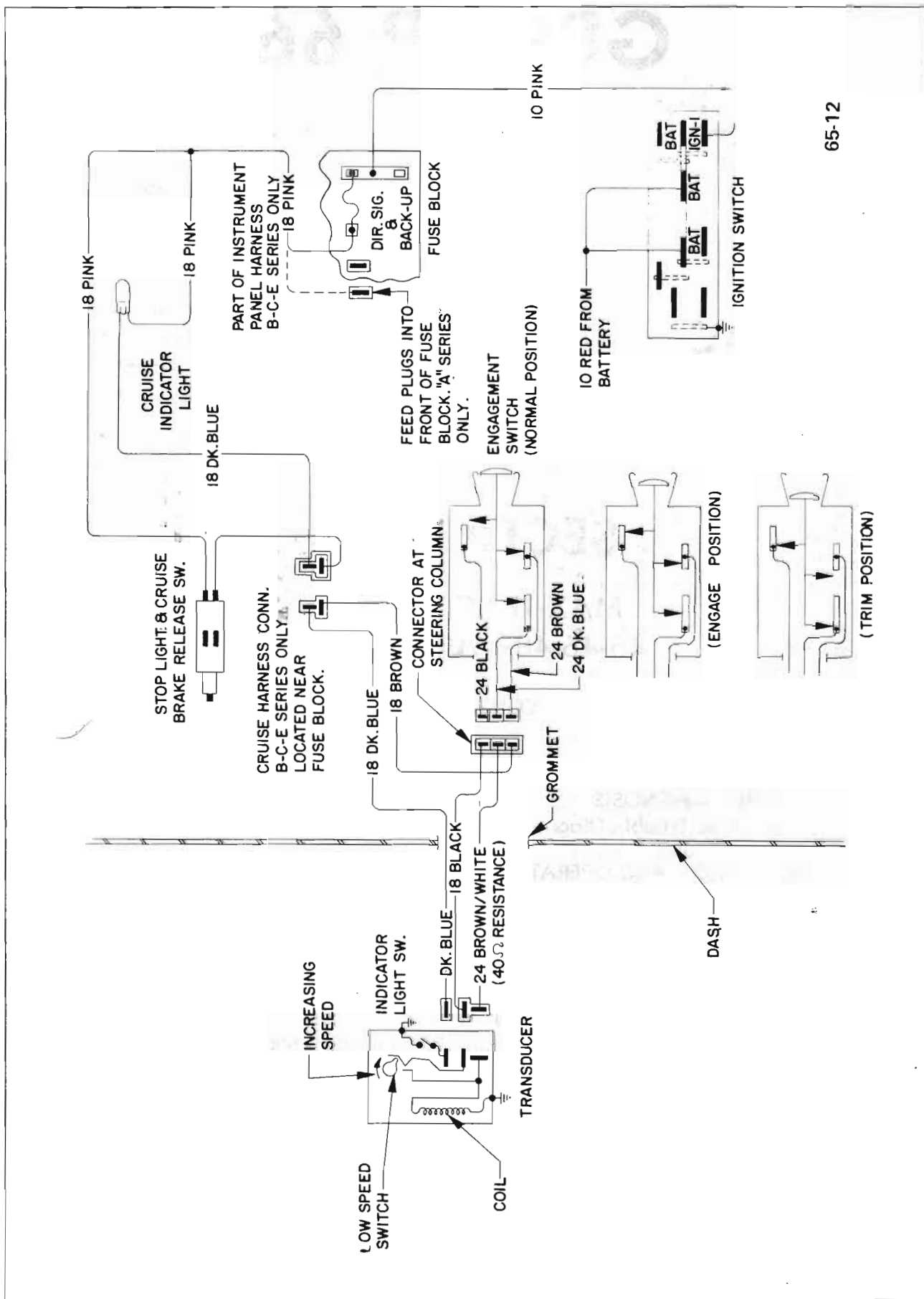

Figure 65-12 - Cruise Master Wiring Diagram